

GLASSVENT® UT WINDOW

Architectural Detail Manual

February 2024

ADME077EN



This page is intentionally left blank.

Table of Contents

Introduction	7
Contacting Kawneer	7
Conventions Used in this Document	8
Product Overview	9
Features	9
Project-Out Window	10
Project-Out Window - 1" Infill	10
CW (Shallow) - Project-Out Window - 1" Infill	11
AW (Deep) - Project-Out Window - 1" Infill	12
Project-Out Window - 1-3/4" Infill	13
CW (Shallow) - Project-Out Window - 1-3/4" Infill	14
AW (Deep) - Project-Out Window - 1-3/4" Infill	15
Accessories - Project-Out Window	16
Outswing Casement Window	17
Outswing Casement Window - 1" Infill	17
CW (Shallow) - Outswing Casement Window - 1" Infill	18
AW (Deep) - Outswing Casement Window - 1" Infill	19
Outswing Casement Window - 1-3/4" Infill	20
CW (Shallow) - Outswing Casement Window - 1-3/4" Infill	21
AW (Deep) - Outswing Casement Window - 1-3/4" Infill	22
Accessories - Outswing Casement Window	23
Thermal Performance	24
Example of Generic Project-Specific U-Factor Calculation	24
Glass Area Chart	24
AW (Deep) - Project-Out Window with 1" Glazing (Warm-Edge Glazing Spacer)	25
System U-factor for Glass Area	26
AW (Deep) - Project-Out Window with 1" Glazing	27
System Solar Heat Gain Coefficient (SHGC) - AW (Deep) - Project-Out Window with 1" Glazing	28
System Visible Transmittance (VT) - AW (Deep) - Project-Out Window with 1" Glazing	29
AW (Deep) - Project-Out Window with 1-3/4" Glazing (Warm-Edge Glazing Spacer)	30
System U-factor for Glass Area	30
AW (Deep) - Project-Out Window with 1-3/4" Glazing	31
System Solar Heat Gain Coefficient (SHGC) - AW (Deep) - Project-Out Window with 1-3/4" Glazing	32
System Visible Transmittance (VT) - AW (Deep) - Project-Out Window with 1-3/4" Glazing	33
AW (Deep) - Outswing Casement Window with 1" Glazing (Warm-Edge Glazing Spacer)	34
System U-factor for Glass Area	34
AW (Deep) - Outswing Casement Window with 1" Glazing	35
System Solar Heat Gain Coefficient (SHGC) - AW (Deep) - Outswing Casement Window with 1" Glazing	36

System Visible Transmittance (VT) - AW (Deep) - Outswing Casement Window with 1" Glazing	37
AW (Deep) - Outswing Casement Window with 1-3/4" Glazing (Warm-Edge Glazing Spacer) ..	38
System U-factor for Glass Area	38
AW (Deep) - Outswing Casement Window with 1-3/4" Glazing	39
System Solar Heat Gain Coefficient (SHGC) - AW (Deep) - Outswing Casement Window with 1-3/4" Glazing	40
System Visible Transmittance (VT) - AW (Deep) - Outswing Casement Window with 1-3/4" Glazing	41
AW (Deep) - Project-Out Window with 1" Glazing (Aluminum Glazing Spacer)	42
System U-factor for Glass Area	42
AW (Deep) - Project-Out Window with 1" Glazing	43
System Solar Heat Gain Coefficient (SHGC) - AW (Deep) - Project-Out Window with 1" Glazing	44
System Visible Transmittance (VT) - AW (Deep) - Project-Out Window with 1" Glazing	45
AW (Deep) - Project-Out Window with 1-3/4" Glazing (Aluminum Glazing Spacer)	46
System U-factor for Glass Area	46
AW (Deep) - Project-Out Window with 1-3/4" Glazing	47
System Solar Heat Gain Coefficient (SHGC) - AW (Deep) - Project-Out Window with 1-3/4" Glazing	48
System Visible Transmittance (VT) - AW (Deep) - Project-Out Window with 1-3/4" Glazing	49
AW (Deep) - Outswing Casement Window with 1" Glazing (Aluminum Glazing Spacer)	50
System U-factor for Glass Area	50
AW (Deep) - Outswing Casement Window with 1" Glazing	51
System Solar Heat Gain Coefficient (SHGC) - AW (Deep) - Outswing Casement Window with 1" Glazing	52
System Visible Transmittance (VT) - AW (Deep) - Outswing Casement Window with 1" Glazing	53
AW (Deep) - Outswing Casement Window with 1-3/4" Glazing (Aluminum Glazing Spacer)	54
System U-factor for Glass Area	54
AW (Deep) - Outswing Casement Window with 1-3/4" Glazing	55
System Solar Heat Gain Coefficient (SHGC) - AW (Deep) - Outswing Casement Window with 1-3/4" Glazing	56
System Visible Transmittance (VT) - AW (Deep) - Outswing Casement Window with 1-3/4" Glazing	57
CW (Shallow) - Project-Out Window with 1" Glazing (Aluminum Glazing Spacer)	58
System U-factor for Glass Area	58
CW (Shallow) - Project-Out Window with 1" Glazing	59
System Solar Heat Gain Coefficient (SHGC) - CW (Shallow) - Project-Out Window with 1" Glazing	60
System Visible Transmittance (VT) - CW (Shallow) - Project-Out Window with 1" Glazing	61
CW (Shallow) - Project-Out Window with 1-3/4" Glazing (Aluminum Glazing Spacer)	62
System U-factor for Glass Area	62
CW (Shallow) - Project-Out Window with 1-3/4" Glazing	63
System Solar Heat Gain Coefficient (SHGC) - CW (Shallow) - Project-Out Window with 1-3/4" Glazing	64

System Visible Transmittance (VT) - CW (Shallow) - Project-Out Window with 1-3/4" Glazing 65

CW (Shallow) - Outswing Casement Window with 1" Glazing (Aluminum Glazing Spacer) 66

System U-factor for Glass Area 66

CW (Shallow) - Outswing Casement Window with 1" Glazing 67

System Solar Heat Gain Coefficient (SHGC) - CW (Shallow) - Outswing Casement Window with 1" Glazing 68

System Visible Transmittance (VT) - CW (Shallow) - Outswing Casement Window with 1" Glazing 69

CW (Shallow) - Outswing Casement Window with 1-3/4" Glazing (Aluminum Glazing Spacer) 70

System U-factor for Glass Area 70

CW (Shallow) - Outswing Casement Window with 1-3/4" Glazing 71

System Solar Heat Gain Coefficient (SHGC) - CW (Shallow) - Outswing Casement Window with 1-3/4" Glazing 72

System Visible Transmittance (VT) - CW (Shallow) - Outswing Casement Window with 1-3/4" Glazing 73

Notes and Disclaimers 74

This page is intentionally left blank.



Introduction

Contacting Kawneer

For contact information, visit www.Kawneer.com.

Conventions Used In This Document

These symbols identify special types of information that can help you use the document more effectively.

Symbol	Description
 NOTE	Denotes general information that provides additional context or guidance
 IMPORTANT	Denotes information to which you should pay special attention
 TIP	Denotes information that can help you perform a task more efficiently

Metric (SI) Conversion. Metric (SI) conversion figures are included throughout this document for reference. Numbers in parentheses () are millimeters unless otherwise noted. The following metric (SI) units may also appear: m – meter; cm – centimeter; mm – millimeter; s – second; Pa – pascal; MPa – megapascal.

Product Overview

**NOTE**

Additional information and CAD details are available at www.Kawneer.com.

Features

For specific product applications, consult your Kawneer representative.

- Commercial Grade Window (CW) and Architectural Grade Window (AW)
- Tested to US and Canadian Standards
- 45° Mitered Vent and Frame Corners
- Staked Corner Joinery
- Architectural Anodized Finishes and Applied Coatings
- Large Missile and Small Missile Hurricane Impact Tested - AW (Deep) only
- Blast Mitigation Tested - AW (Deep) only

Project-Out Window

Project-Out Window - 1" Infill

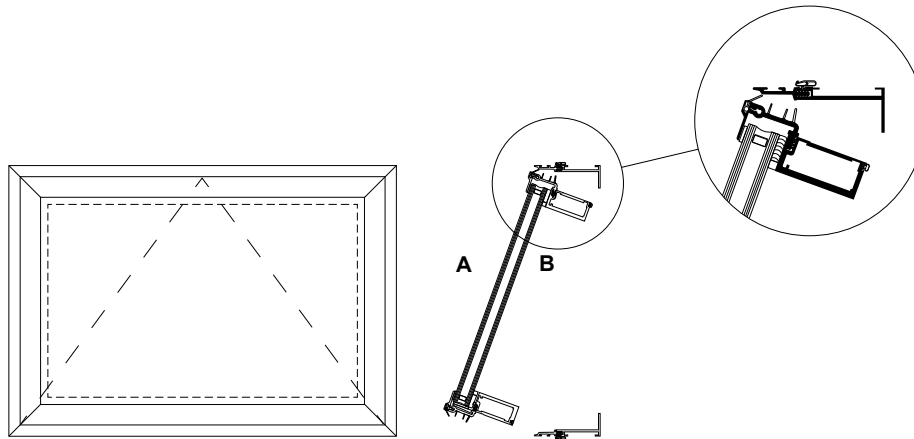

- A. Exterior
B. Interior

CLASS and GRADE	CLASS CW-PG70-AP / AW-PG90-AP
TESTING STANDARD	AAMA / WDMA / CSA / 101 / I.S.2 / A440 (NAFS)
SYSTEM DEPTH	CW (Shallow) - 3-1/8" / AW (Deep) - 4-3/8" Overall System Depth
TYPICAL WALL THICKNESS	CW (Shallow) - .125 Nominal Frame / .100" Nominal Vent AW (Deep) - .125 Nominal Frame / .156" Nominal Vent
TYPICAL MAX. VENT SIZE	CW (Shallow) - 48" x 32" / AW (Deep) - 60" x 36"
TYPICAL MIN. VENT SIZE	17" x 17"
INFILL OPTIONS	1"
STANDARD HARDWARE	Stainless Steel 4-Bar Hinges Cast White Bronze Cam Handles
OPTIONAL HARDWARE	Access Control Locks Hook Bolt Lock Handle Pivot Shoe Roto-Operator (Size Limitations - Minimum 26" Wide x 17" High, Maximum 60" Wide x 36" High) (Verify with application engineering project specific limit stop requirements based on window size) Limit Stop (Verify with application engineering project specific limit stop requirements based on window size) Pole and Pole Ring Omni Drive (5 lb) operating force. <ul style="list-style-type: none"> • AW (Deep version 1" infill) • (Consult Application Engineering on project specific application)
OTHER OPTIONS	Insect Screens

CW (Shallow) - Project-Out Window - 1" Infill

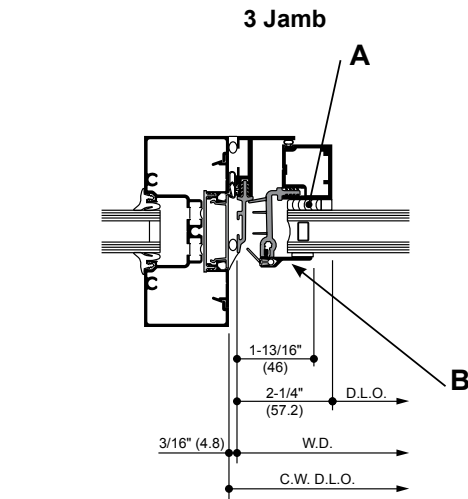
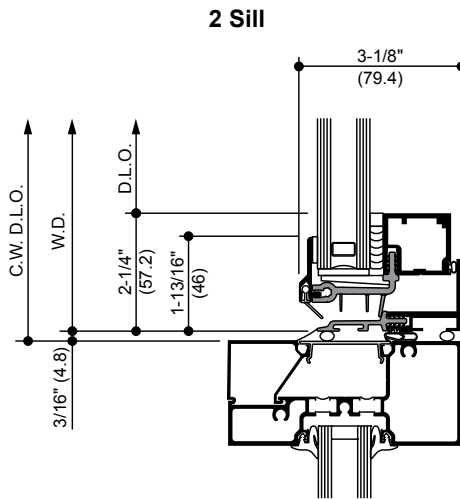
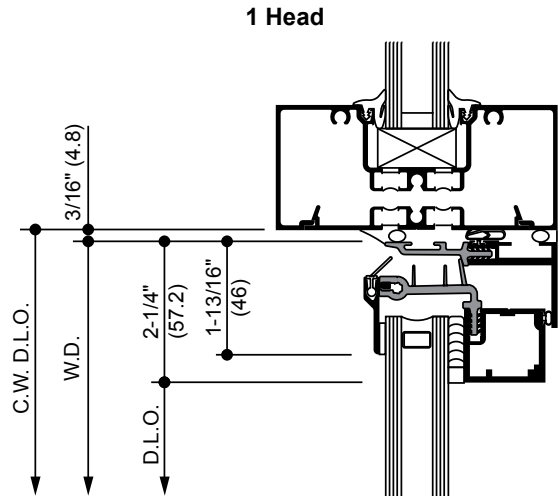
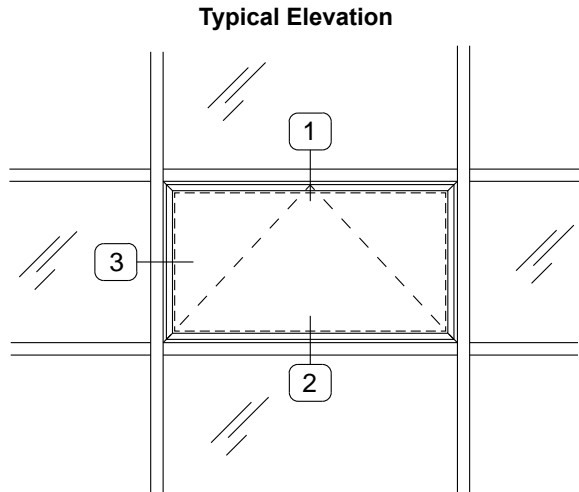

- A. Structural Silicone Sealant (by Others)*
- B. Trim Cap available in #29 Black anodized finish only.

NOTICE
 * Installer is responsible for all required compatibility review and approvals with the Structural Silicone Manufacturer and the Insulating Glass Unit Manufacturer.

NOTE
 The Kawneer GLASSvent® UT Window is shown with Trifab® 451UT Framing System for reference. Other Kawneer systems can be used. For product specific applications, consult your Kawneer representative.

AW (Deep) - Project-Out Window - 1" Infill

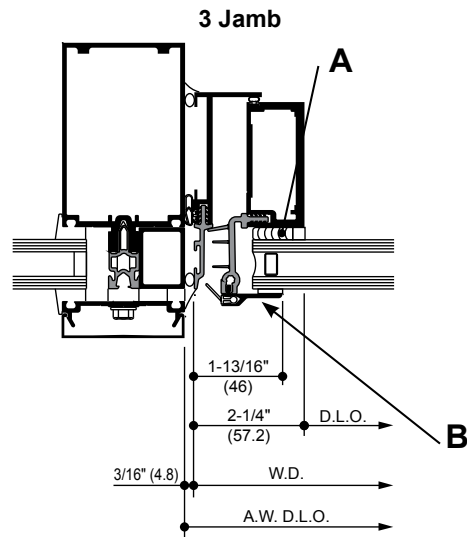
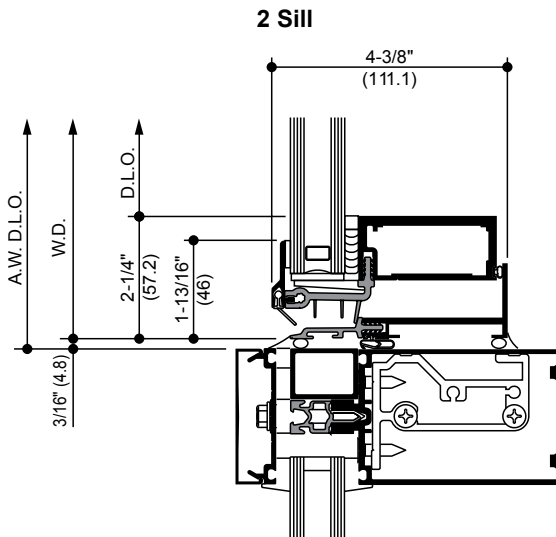
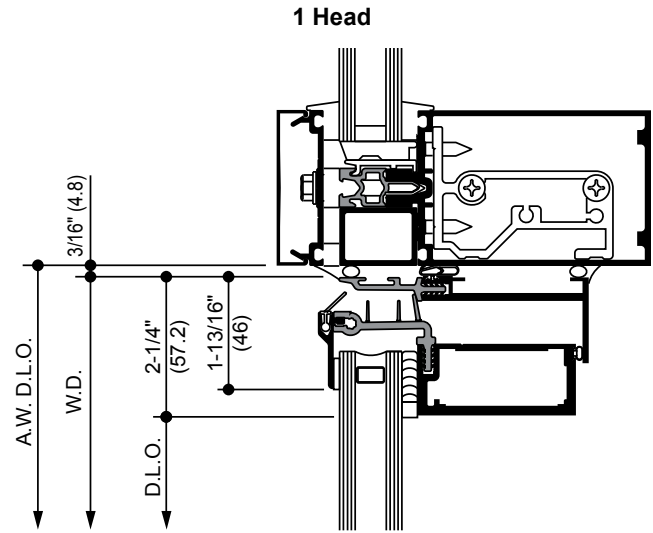
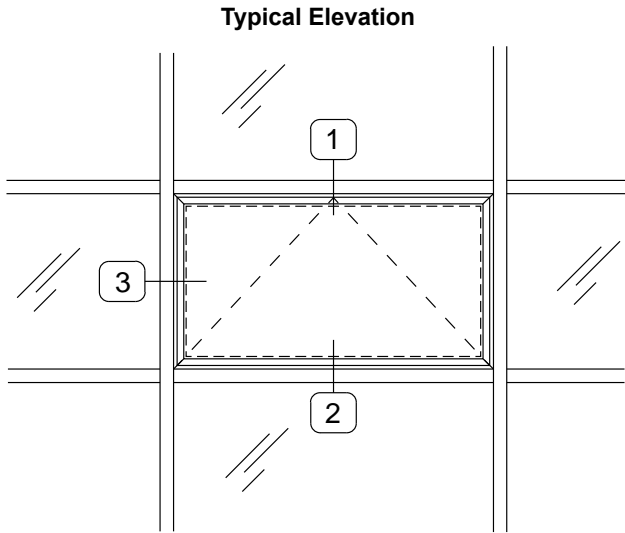

- A. Structural Silicone Sealant (by Others)*
- B. Trim Cap available in #29 Black anodized finish only.

NOTICE
 * Installer is responsible for all required compatibility review and approvals with the Structural Silicone Manufacturer and the Insulating Glass Unit Manufacturer.

NOTE
 The Kawneer GLASSvent® UT Window is shown with 1600UT Framing System®1 Curtain Wall for reference. Other Kawneer systems can be used. For product specific applications, consult your Kawneer representative.

Project-Out Window - 1-3/4" Infill

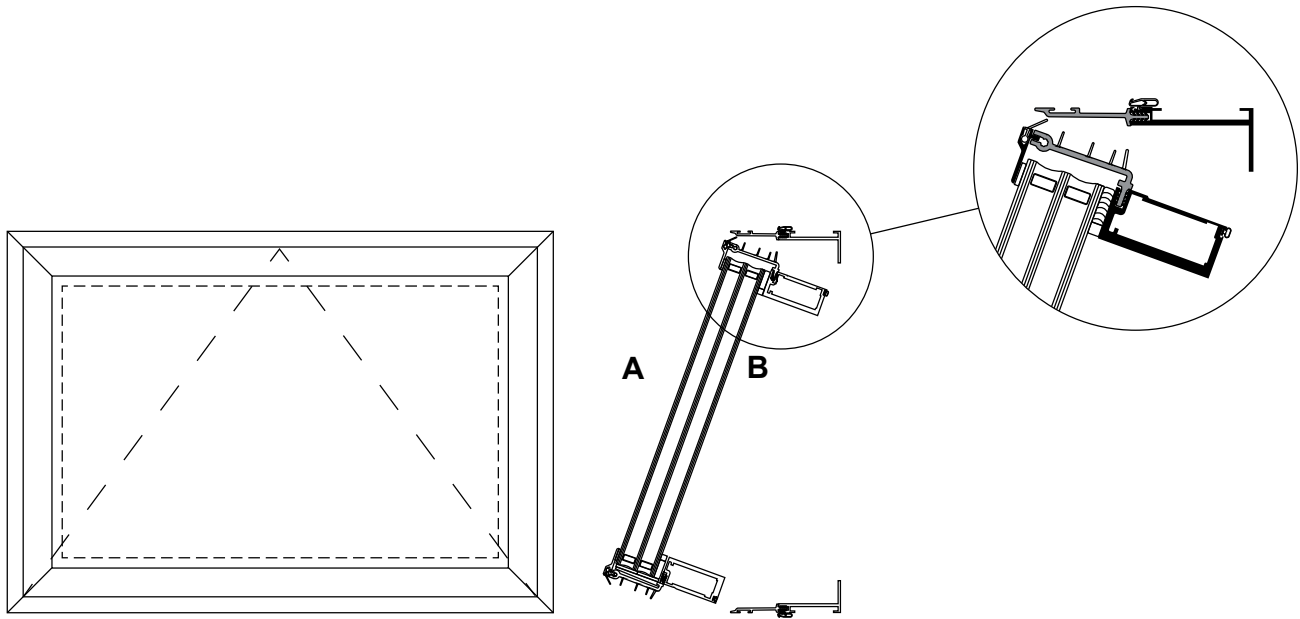

- A. Exterior
- B. Interior

CLASS and GRADE	CLASS CW-PG70-AP / AW-PG90-AP
TESTING STANDARD	AAMA / WDMA / CSA / 101 / I.S.2 / A440 (NAFS)
SYSTEM DEPTH	CW (Shallow) - 3-7/8" / AW (Deep) - 5-1/8" Overall System Depth
TYPICAL WALL THICKNESS	CW (Shallow) - .125 Nominal Frame / .100" Nominal Vent AW (Deep) - .125 Nominal Frame / .156" Nominal Vent
TYPICAL MAX. VENT SIZE	CW (Shallow) - 48" x 32" / AW (Deep) - 60" x 36"
TYPICAL MIN. VENT SIZE	17" x 17"
INFILL OPTIONS	1-3/4"
STANDARD HARDWARE	Stainless Steel 4-Bar Hinges Cast White Bronze Cam Handles
OPTIONAL HARDWARE	Access Control Locks Hook Bolt Lock Handle Pivot Shoe Roto-Operator (Size Limitations - Minimum 26" Wide x 17" High, Maximum 60" Wide x 36" High) (Verify with application engineering project specific limit stop requirements based on window size) Limit Stop (Verify with application engineering project specific limit stop requirements based on window size) Pole and Pole Ring
OTHER OPTIONS	Insect Screens

CW (Shallow) - Project-Out Window - 1-3/4" Infill

Typical Elevation

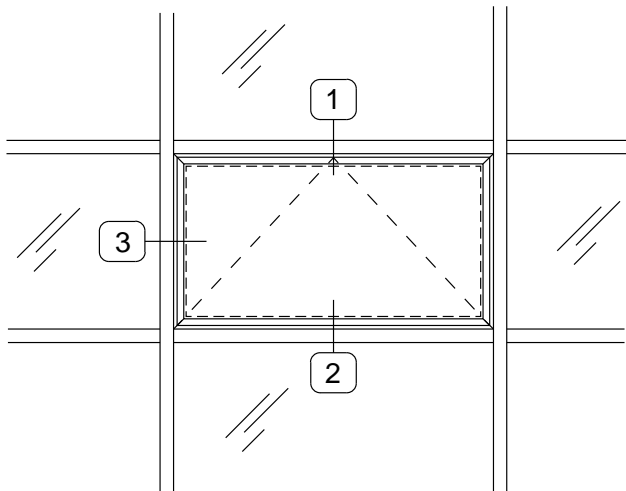

1 Head

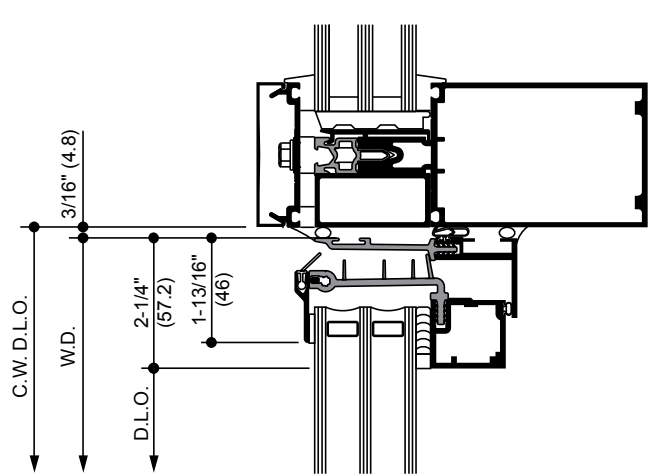

2 Sill

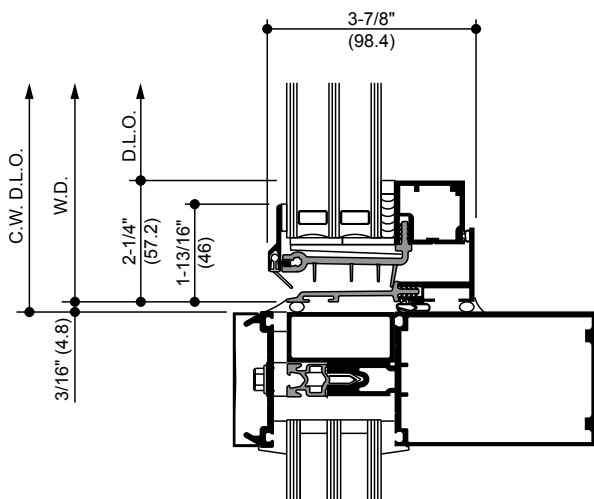

3 Jamb

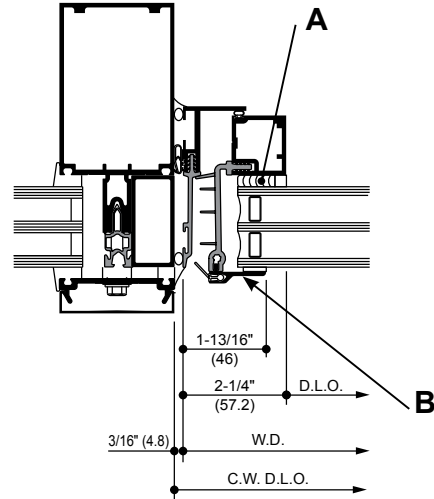

- A. Structural Silicone Sealant (by Others)*
- B. Trim Cap available in #29 Black anodized finish only.



NOTICE

* Installer is responsible for all required compatibility review and approvals with the Structural Silicone Manufacturer and the Insulating Glass Unit Manufacturer.



NOTE

The Kawneer GLASSvent® UT Window is shown with 1600UT Framing System®1 Curtain Wall for reference. Other Kawneer systems can be used. For product specific applications, consult your Kawneer representative.

AW (Deep) - Project-Out Window - 1-3/4" Infill

Typical Elevation

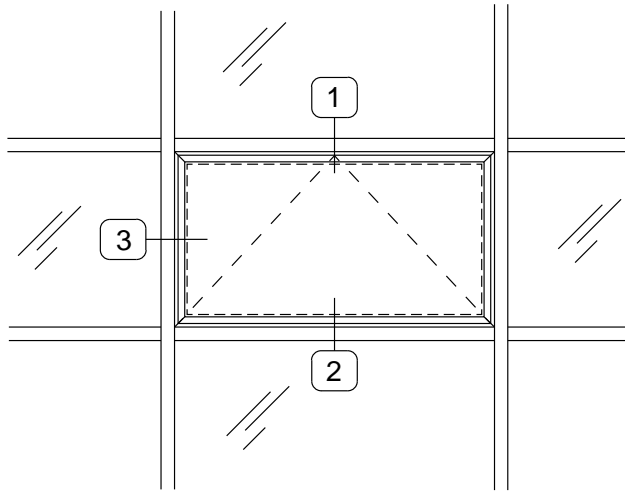

1 Head

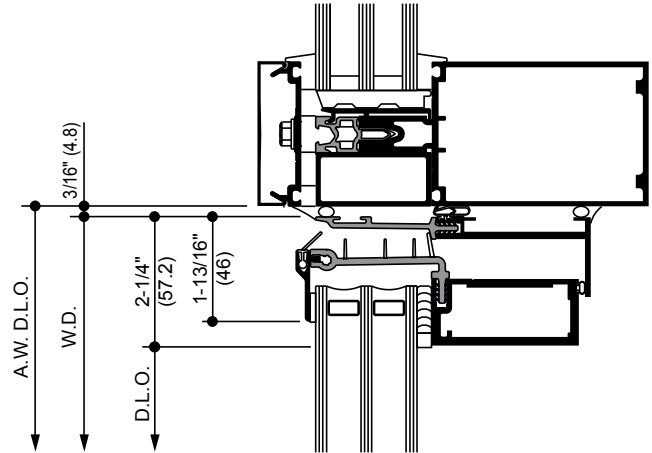

2 Sill

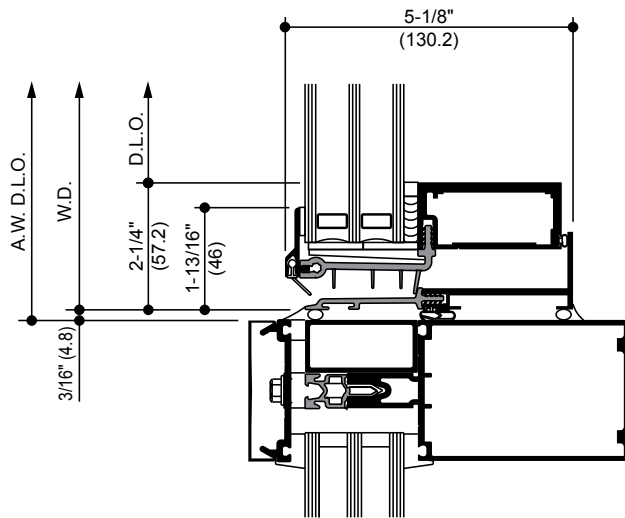

3 Jamb

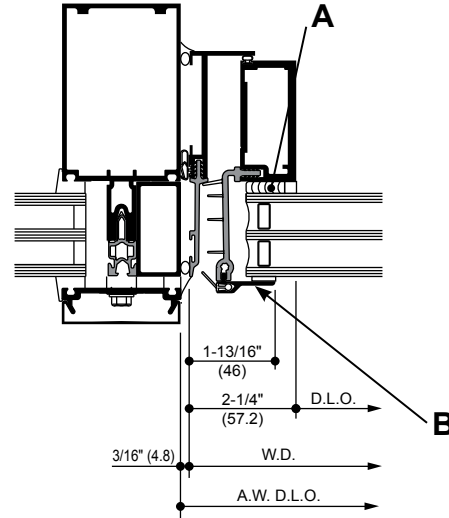

- A. Structural Silicone Sealant (by Others)*
- B. Trim Cap available in #29 Black anodized finish only.



NOTICE









* Installer is responsible for all required compatibility review and approvals with the Structural Silicone Manufacturer and the Insulating Glass Unit Manufacturer.

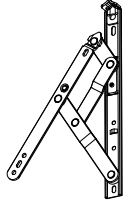

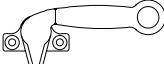
NOTE

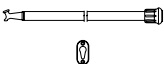
The Kawneer GLASSvent® UT Window is shown with 1600UT Framing System®1 Curtain Wall for reference. Other Kawneer systems can be used. For product specific applications, consult your Kawneer representative.

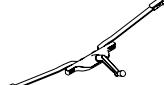
Accessories - Project-Out Window

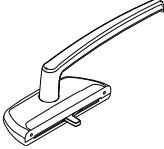
STAINLESS STEEL 4 BAR HINGES		<p>A standard hinge for ventilators providing approximately 45° to 60° openings depending on size. An optional limit stop is available to restrict hinge travel and limit vent opening.</p>
CAM HANDLE		<p>Cast white bronze cam handles are standard for the manual operation and locking of ventilators.</p>
CAM HANDLE WITH POLE RING		<p>Cast white bronze cam handles with pole ring provide manual operation of ventilators located above reach. These handles are operated with a sash pole.</p>
POLE RING		<p>Cast white bronze pole ring is used in conjunction with locking hardware for sash pole operation of ventilators.</p>
SASH POLE AND HANGER		<p>A 3/4" diameter aluminum sash pole with a cast white bronze pull down hook and black rubber tip. Available in 6 ft. and 12 ft. lengths with optional cast white bronze Pole Hanger.</p>
ACCESS CONTROL LOCK		<p>In lieu of cam handles cast white bronze access control locks are offered for managed control of vent operations. Lock is operated with a manganese bronze removable handle.</p>
PIVOT-SHOE ROTO- OPERATOR		<p>Optional pivot shoe roto operator is located on the center line of the bottom horizontal frame. Standard finish shall be gray.</p>
HOOK BOLT LOCK		<p>For use with pivot-shoe roto operator in lieu of cam handles. Standard finish shall be US-25-D clear white bronze.</p>
OMNI DRIVE HANDLE		<p>Omni Drive hardware to support 5 lb operating force lock handle. Powder coat: black or white.</p>

Outswing Casement Window

Outswing Casement Window - 1" Infill

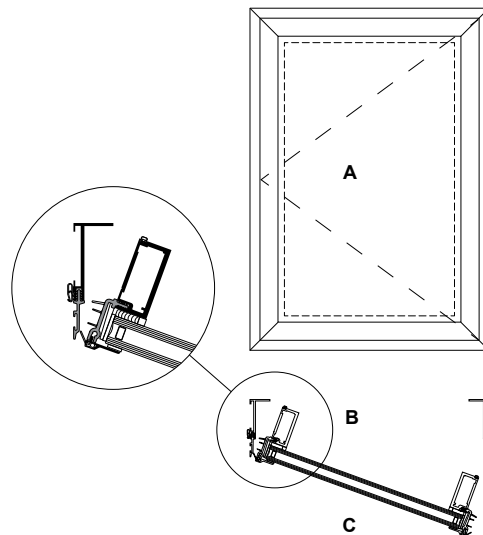

- A. Hinged Left
- B. Interior
- C. Exterior

CLASS and GRADE	CLASS CW-PG70-C / AW-PG90-C
TESTING STANDARD	AAMA / WDMA / CSA / 101 / I.S.2 / A440 (NAFS)
SYSTEM DEPTH	CW (Shallow) - 3-1/8" / AW (Deep) - 4-3/8" Overall System Depth
TYPICAL WALL THICKNESS	CW (Shallow) - .125 Nominal Frame / .100" Nominal Vent AW (Deep) - .125 Nominal Frame / .156" Nominal Vent
TYPICAL MAX. VENT SIZE	CW (Shallow) - 32" x 48" / AW (Deep) - 36" x 60"
TYPICAL MIN. VENT SIZE	17" x 24"
INFILL OPTIONS	1"
STANDARD HARDWARE	Stainless Steel 4-Bar Hinges Cast White Bronze Cam Handles
OPTIONAL HARDWARE	Access Control Locks Hook Bolt Lock or Multi-Point Lock Roto Operator (Size Limitations - Minimum 25" Wide x 24" High, Maximum 36" Wide x 60" High) (Verify with application engineering project specific limit stop requirements based on window size) Limit Stop (Verify with application engineering project specific limit stop requirements based on window size) Pole and Pole Ring
OTHER OPTIONS	Insect Screens

CW (Shallow) - Outswing Casement Window - 1" Infill

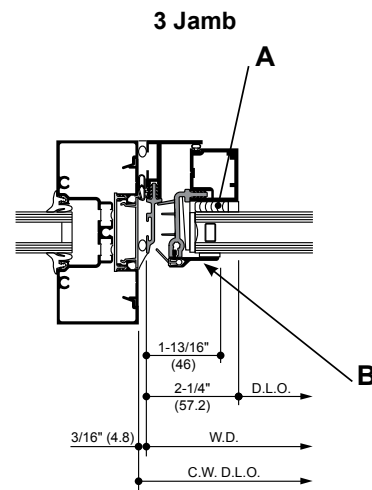
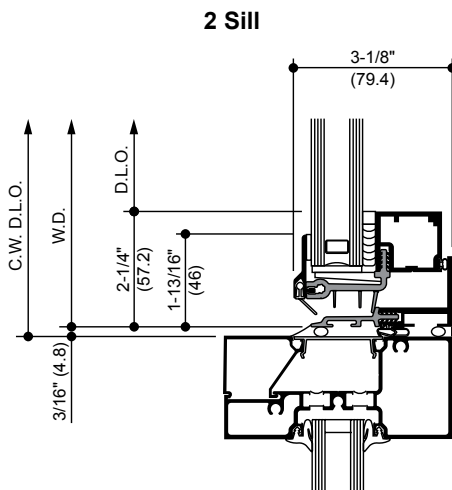
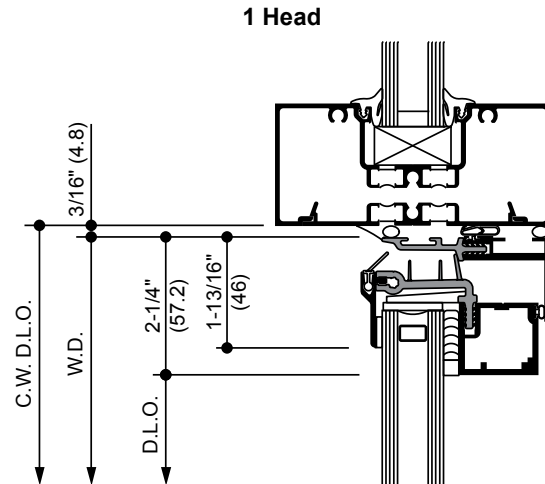
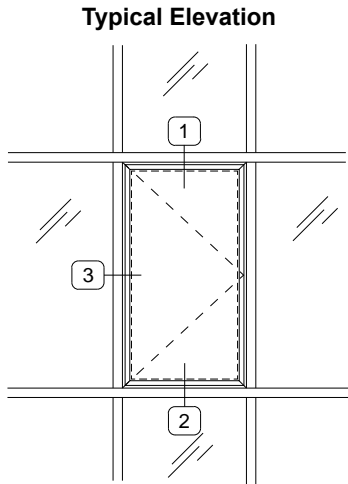

- A. Structural Silicone Sealant (by Others)*
- B. Trim Cap available in #29 Black anodized finish only.



NOTICE

* Installer is responsible for all required compatibility review and approvals with the Structural Silicone Manufacturer and the Insulating Glass Unit Manufacturer.



NOTE

The Kawneer GLASSvent® UT Window is shown with Trifab® 451UT Framing System for reference. Other Kawneer systems can be used. For product specific applications, consult your Kawneer representative.

AW (Deep) - Outswing Casement Window - 1" Infill

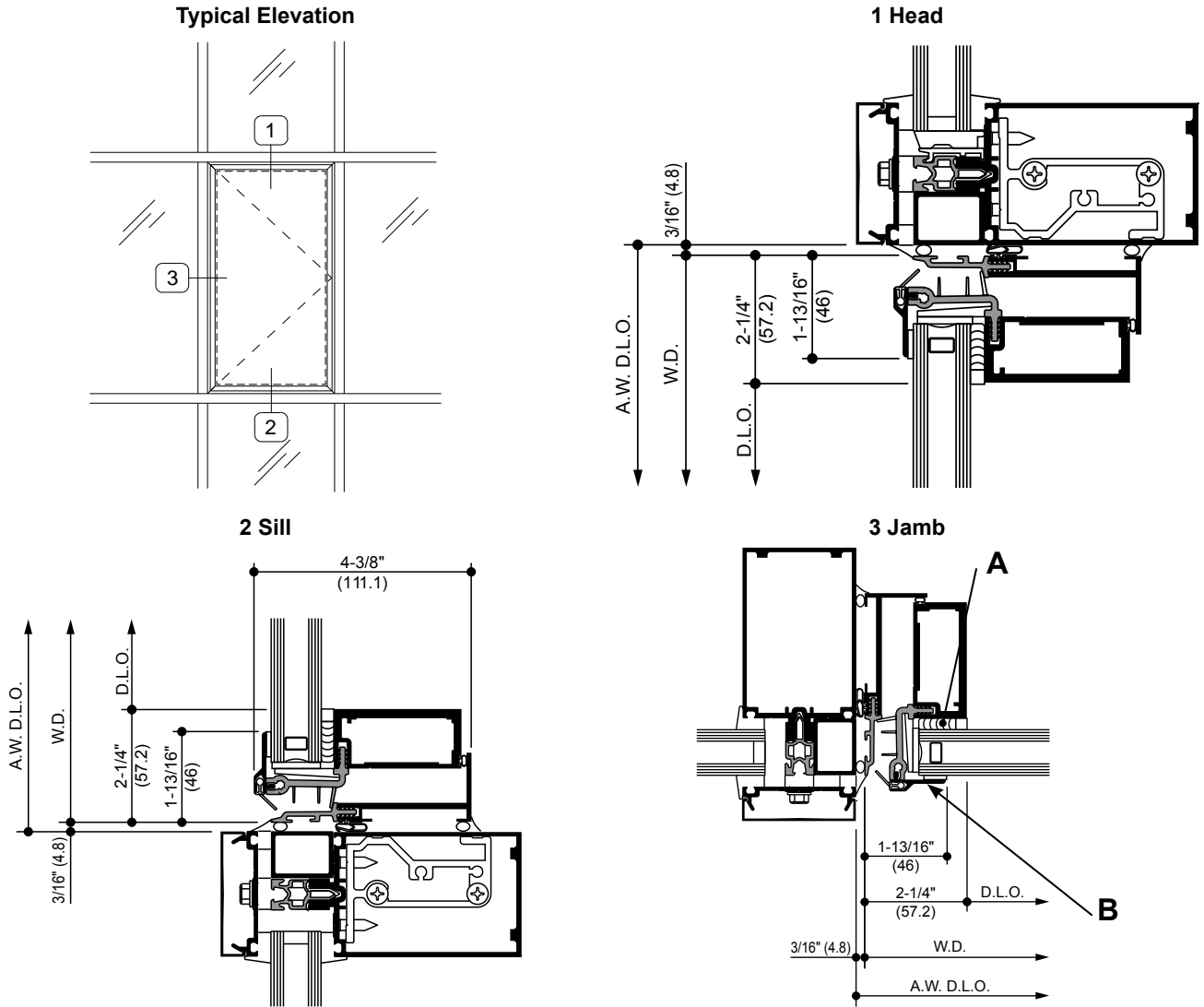

- A. Structural Silicone Sealant (by Others)*
- B. Trim Cap available in #29 Black anodized finish only.

NOTICE
 * Installer is responsible for all required compatibility review and approvals with the Structural Silicone Manufacturer and the Insulating Glass Unit Manufacturer.

NOTE
 The Kawneer GLASSvent® UT Window is shown with 1600UT Framing System®1 Curtain Wall for reference. Other Kawneer systems can be used. For product specific applications, consult your Kawneer representative.

Outswing Casement Window - 1-3/4" Infill

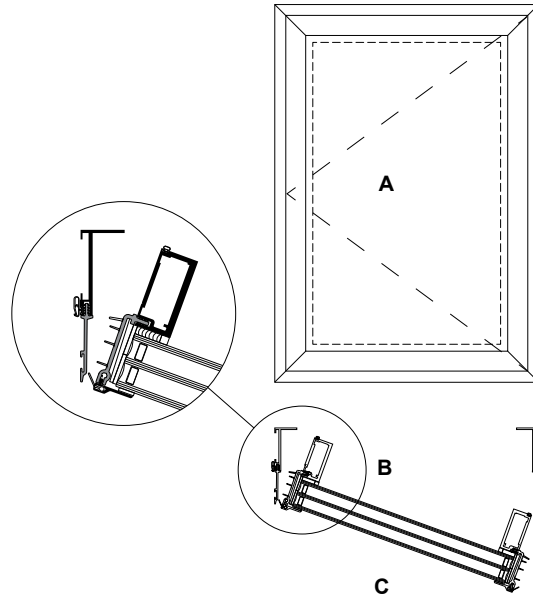

- A. Hinged Left
- B. Interior
- C. Exterior

CLASS and GRADE	CLASS CW-PG70-C / AW-PG90-C
TESTING STANDARD	AAMA / WDMA / CSA / 101 / I.S.2 / A440 (NAFS)
SYSTEM DEPTH	CW (Shallow) - 3-7/8" / AW (Deep) - 5-1/8" Overall System Depth
TYPICAL WALL THICKNESS	CW (Shallow) - .125 Nominal Frame / .100" Nominal Vent AW (Deep) - .125 Nominal Frame / .156" Nominal Vent
TYPICAL MAX. VENT SIZE	CW (Shallow) - 32" x 48" / AW (Deep) - 36" x 60"
TYPICAL MIN. VENT SIZE	17" x 24"
INFILL OPTIONS	1-3/4"
STANDARD HARDWARE	Stainless Steel 4-Bar Hinges Cast White Bronze Cam Handles
OPTIONAL HARDWARE	Access Control Locks Hook Bolt Lock or Multi-Point Lock Limit Stop (Verify with application engineering project specific limit stop requirements based on window size) Pole and Pole Ring Roto Operator (Size Limitations - Minimum 25" Wide x 24" High, Maximum 36" Wide x 60" High) (Verify with application engineering project specific limit stop requirements based on window size)
OTHER OPTIONS	Insect Screens

CW (Shallow) - Outswing Casement Window - 1-3/4" Infill

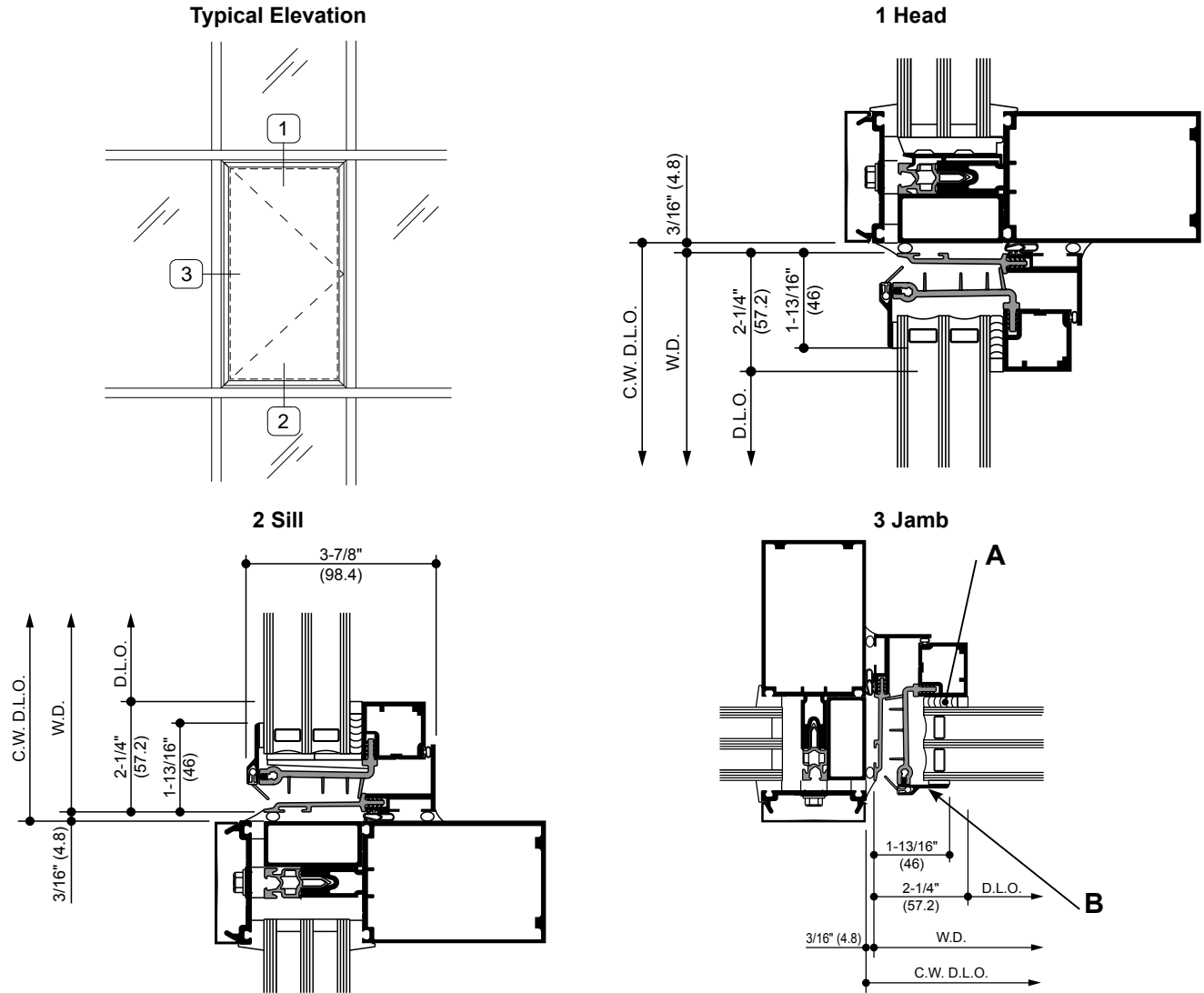

- A. Structural Silicone Sealant (by Others)*
- B. Trim Cap available in #29 Black anodized finish only.

NOTICE
 * Installer is responsible for all required compatibility review and approvals with the Structural Silicone Manufacturer and the Insulating Glass Unit Manufacturer.

NOTE
 The Kawneer GLASSvent® UT Window is shown with 1600UT Framing System®1 Curtain Wall for reference. Other Kawneer systems can be used. For product specific applications, consult your Kawneer representative.

AW (Deep) - Outswing Casement Window - 1-3/4" Infill

Typical Elevation

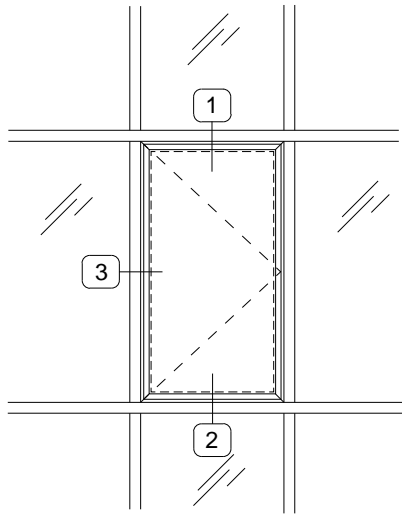

1 Head

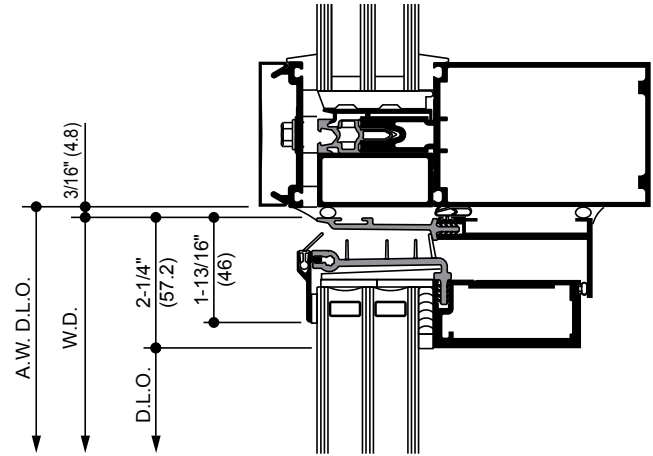

2 Sill

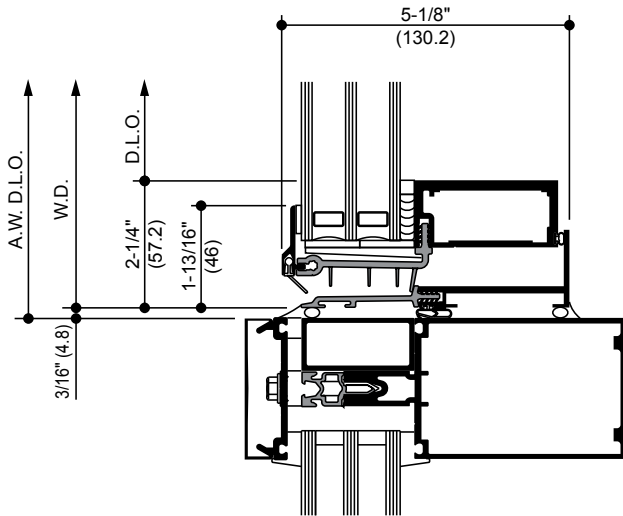

3 Jamb

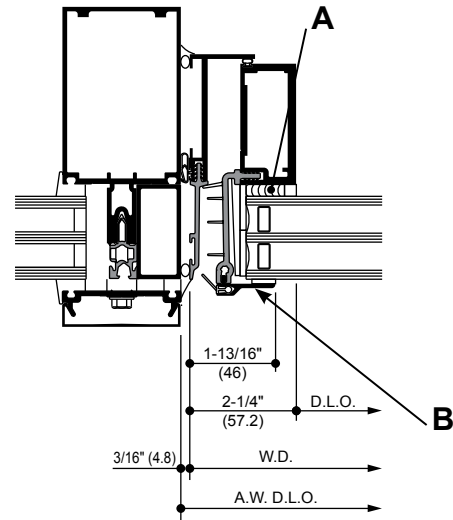

- A. Structural Silicone Sealant (by Others)*
- B. Trim Cap available in #29 Black anodized finish only.



NOTICE





* Installer is responsible for all required compatibility review and approvals with the Structural Silicone Manufacturer and the Insulating Glass Unit Manufacturer.

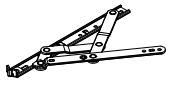
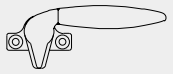
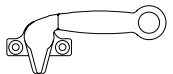

NOTE

The Kawneer GLASSvent® UT Window is shown with 1600UT Framing System®1 Curtain Wall for reference. Other Kawneer systems can be used. For product specific applications, consult your Kawneer representative.

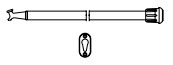
Accessories - Outswing Casement Window

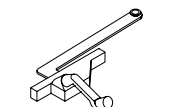
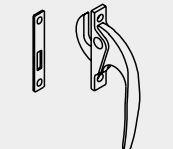
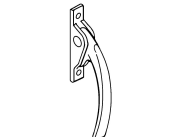
STAINLESS STEEL 4 BAR HINGES		<p>A standard hinge for ventilators providing an opening of up to 45°. An optional limit stop is available to restrict hinge travel and limit vent opening.</p>
CAM HANDLE		<p>Cast white bronze cam handles are standard for the manual operation and locking of ventilators.</p>
CAM HANDLE WITH POLE RING		<p>Cast white bronze cam handles with pole ring provide manual operation of ventilators located above reach. These handles are operated with a sash pole.</p>
POLE RING		<p>Cast white bronze pole ring is used in conjunction with locking hardware for sash pole operation of ventilators.</p>
SASH POLE AND HANGER		<p>A 3/4" diameter aluminum sash pole with a cast white bronze pull down hook and black rubber tip. Available in 6 ft. and 12 ft. lengths with optional cast white bronze Pole Hanger.</p>
ACCESS CONTROL LOCK		<p>In lieu of cam handles cast white bronze access control locks are offered for managed control of vent operations. Lock is operated with a manganese bronze removable handle.</p>
ROTO-OPERATOR		<p>Roto operators are used with butt hinges only and located at the bottom horizontal frame. Standard finish shall be brushed copper nickel to match US-25-D.</p>
HOOK BOLT LOCK		<p>Optional hook bolt lock in lieu of cam handle. Standard finish shall be US-25-D clear white bronze.</p>
MULTI-POINT LOCK		<p>Optional single locking handle for concealed multipoint locks located on the vertical frame. Standard finish shall be US-25-D clear white bronze.</p>

Thermal Performance

Example of Generic Project-Specific U-Factor Calculation



NOTE

The percent of glass will vary on specific products, depending on sightlines.

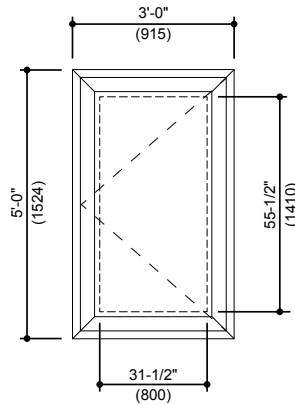

Example Glass U-factor	= 0.28 Btu/(ft ² • h • °F)
Total Daylight Opening	= 31-1/2" • 55-1/2" = 12.14 ft ²
Total Projected Area	= 3'0" • 5' 0" = 15 ft ²
Percentage of Glass	= (Total Daylight Opening ÷ Total Projected Area) • 100
	= (12.14 ÷ 15) • 100 = 81%

Glass Area Chart

Based on 81% glass and center-of-glass U-factor of 0.28, the system U-factor is equal to 0.38 Btu/(h • ft² • °F).

System U-factor vs Percent of Glass Area

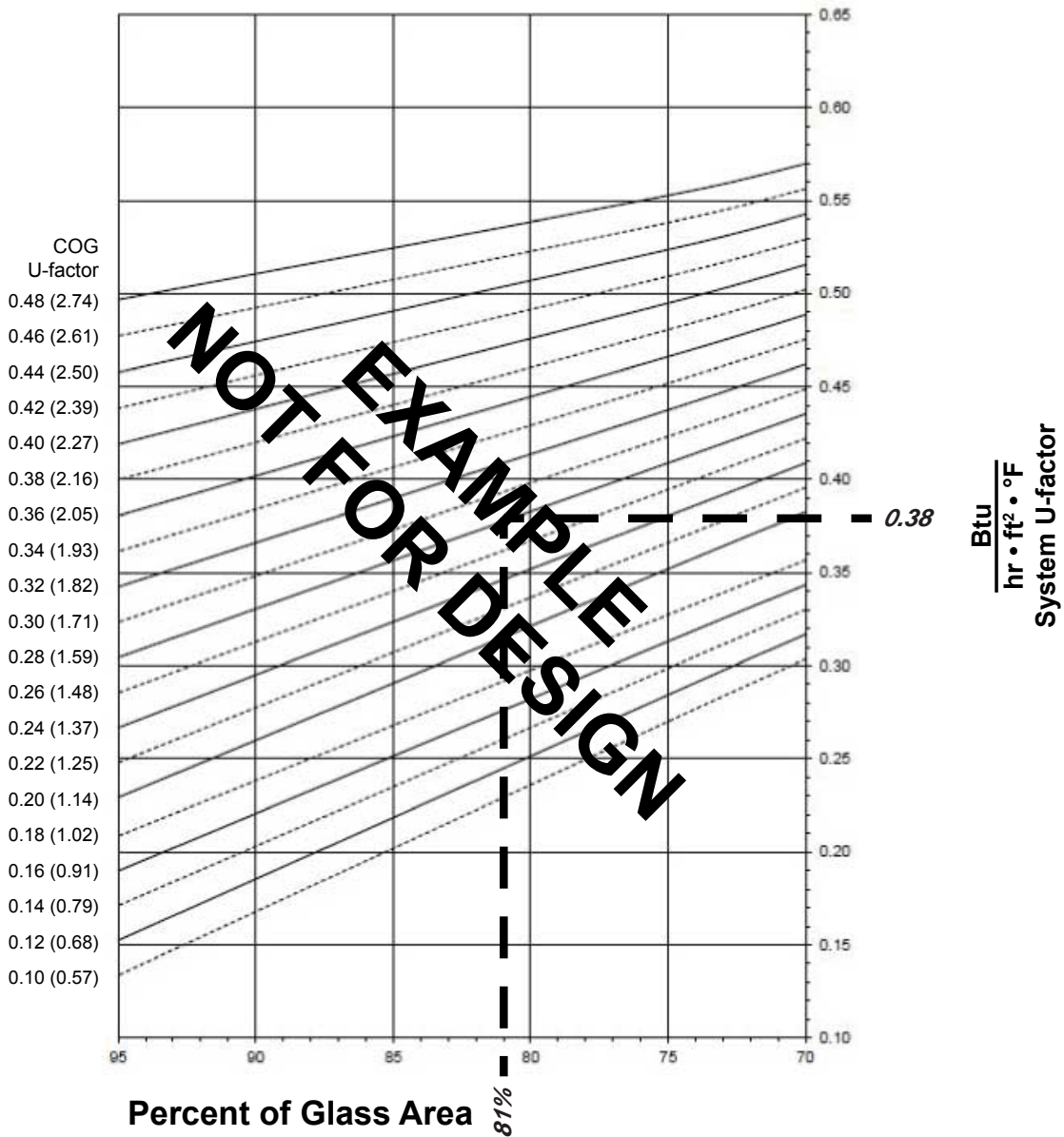

AW (Deep) - Project-Out Window with 1" Glazing (Warm-Edge Glazing Spacer)



NOTE

These notes apply to the charts for system U-factor, solar heat gain coefficient (SHGC), and visible transmittance (VT):

- Values in parentheses are metric.
- COG = Center of Glass
- Charts are generated per AAMA 507.
- For glass values that are not listed, linear interpolation is permitted.
- Glass properties are based on center-of-glass values and are obtained from your glass supplier.

System U-factor for Glass Area

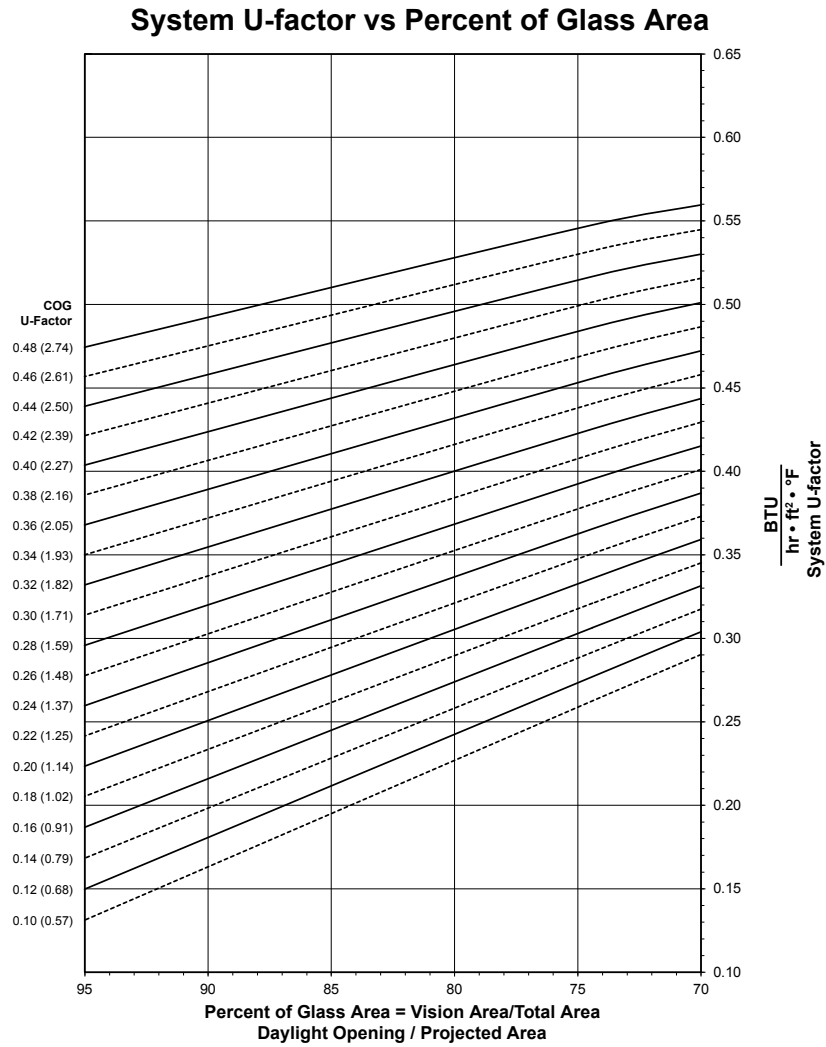

See Note, page 25.

AW (Deep) - Project-Out Window with 1" Glazing**Thermal Transmittance (BTU/hr • ft² • °F)**

Glass U-factor ^{a. b. c.}	Overall U-factor ^{d.}
0.48	0.55
0.46	0.53
0.44	0.52
0.42	0.50
0.40	0.49
0.38	0.47
0.36	0.46
0.34	0.44
0.32	0.43
0.30	0.41
0.28	0.40
0.26	0.38
0.24	0.37
0.22	0.35
0.20	0.34

^{a.}U-factor values are determined in accordance with NFRC 100.

^{b.}For glass values that are not listed, linear interpolation is permitted.

^{c.}Glass properties are based on center-of-glass values and are obtained from your glass supplier.

^{d.}Overall U-factor values are based on the standard NFRC specimen size of 1,500 mm wide by 600 mm high (59-1/6" by 23-5/8").

System Solar Heat Gain Coefficient (SHGC) - AW (Deep) - Project-Out Window with 1" Glazing

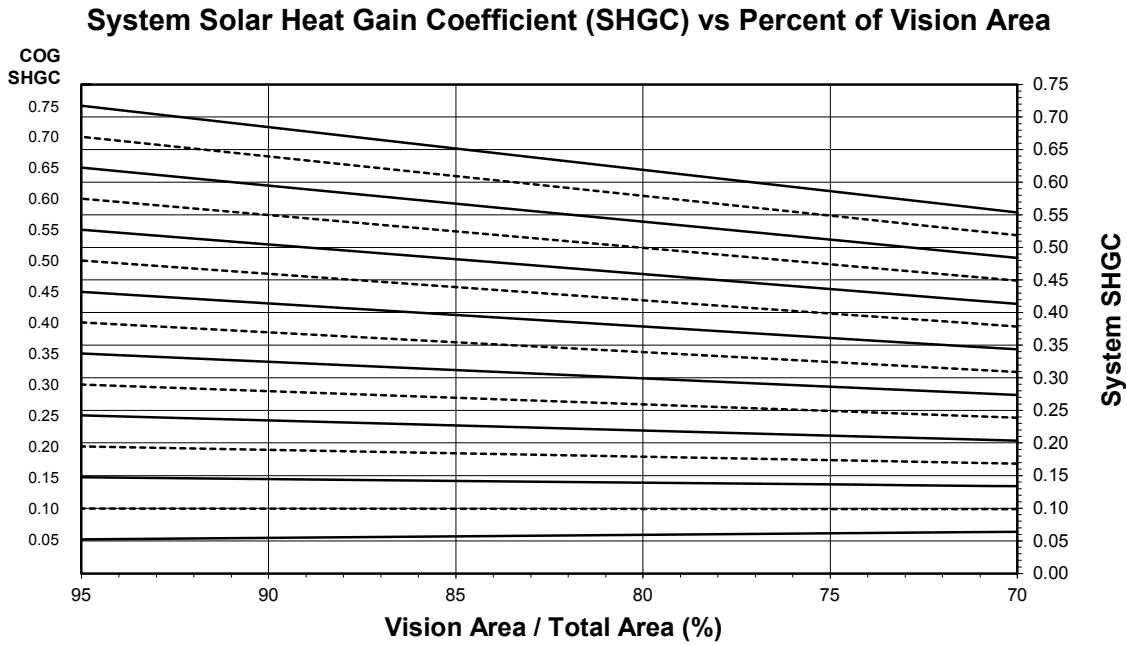

See [Note, page 25](#).

Solar Heat Gain Coefficient (SHGC) Matrix

Glass SHGC ^{a. b. c.}	Overall SHGC ^{d.}
0.75	0.58
0.70	0.55
0.65	0.51
0.60	0.47
0.55	0.43
0.50	0.40
0.45	0.36
0.40	0.32
0.35	0.28
0.30	0.25
0.25	0.21
0.20	0.17
0.15	0.14
0.10	0.10
0.05	0.06

^{a.} SHGC values are determined in accordance with NFRC 200.

^{b.} For glass values that are not listed, linear interpolation is permitted.

^{c.} Glass properties are based on center-of-glass values and are obtained from your glass supplier.

^{d.} Overall SHGC values are based on the standard NFRC specimen size of 1,500 mm wide by 600 mm high (59-1/6" by 23-5/8").

System Visible Transmittance (VT) - AW (Deep) - Project-Out Window with 1" Glazing

System Visible Transmittance (VT) vs Percent of Vision Area

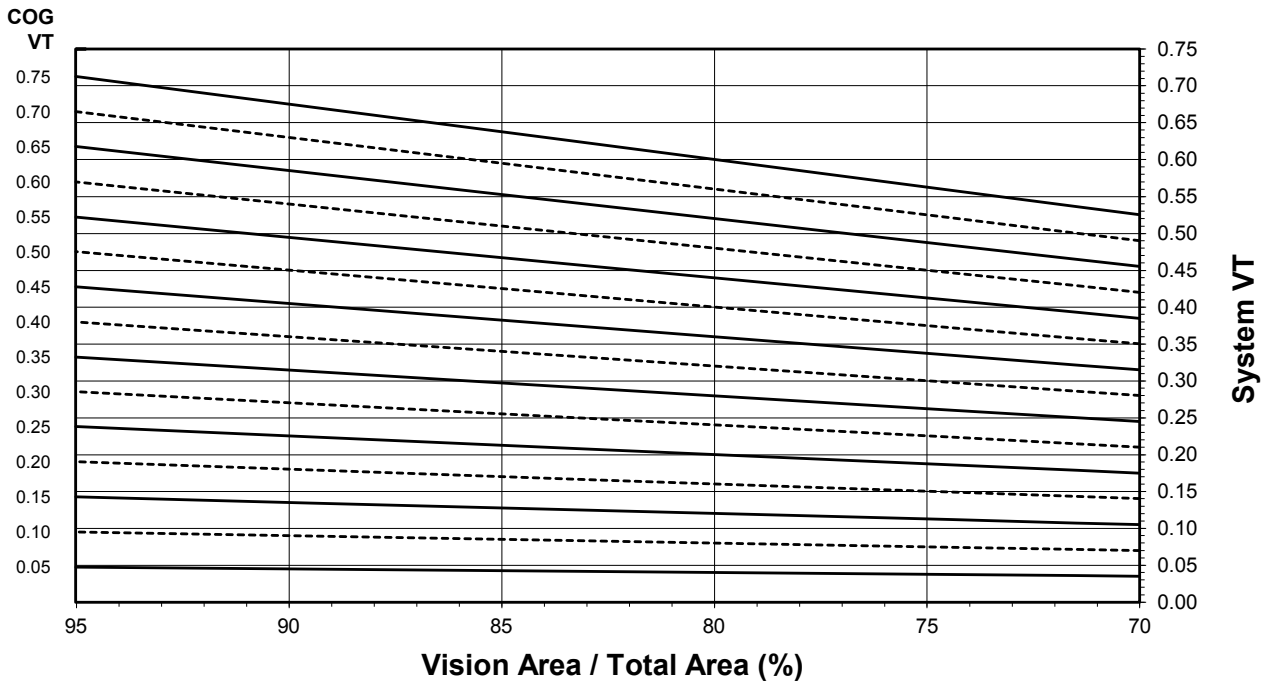

See [Note, page 25](#).

Visible Transmittance (VT)

Glass VT ^{a. b. c.}	Overall VT ^{d.}
0.75	0.56
0.70	0.52
0.65	0.48
0.60	0.45
0.55	0.41
0.50	0.37
0.45	0.33
0.40	0.30
0.35	0.26
0.30	0.22
0.25	0.19
0.20	0.15
0.15	0.11
0.10	0.07
0.05	0.04

^{a.} VT values are determined in accordance with NFRC 200.

^{b.} For glass values that are not listed, linear interpolation is permitted.

^{c.} Glass properties are based on center-of-glass values and are obtained from your glass supplier.

^{d.} Overall VT values are based on the standard NFRC specimen size of 1,500 mm wide by 600 mm high (59-1/6" by 23-5/8").

AW (Deep) - Project-Out Window with 1-3/4" Glazing (Warm-Edge Glazing Spacer)



NOTE

These notes apply to the charts for system U-factor, solar heat gain coefficient (SHGC), and visible transmittance (VT):

- Values in parentheses are metric.
- COG = Center of Glass
- Charts are generated per AAMA 507.
- For glass values that are not listed, linear interpolation is permitted.
- Glass properties are based on center-of-glass values and are obtained from your glass supplier.

System U-factor for Glass Area

System U-factor vs Percent of Glass Area

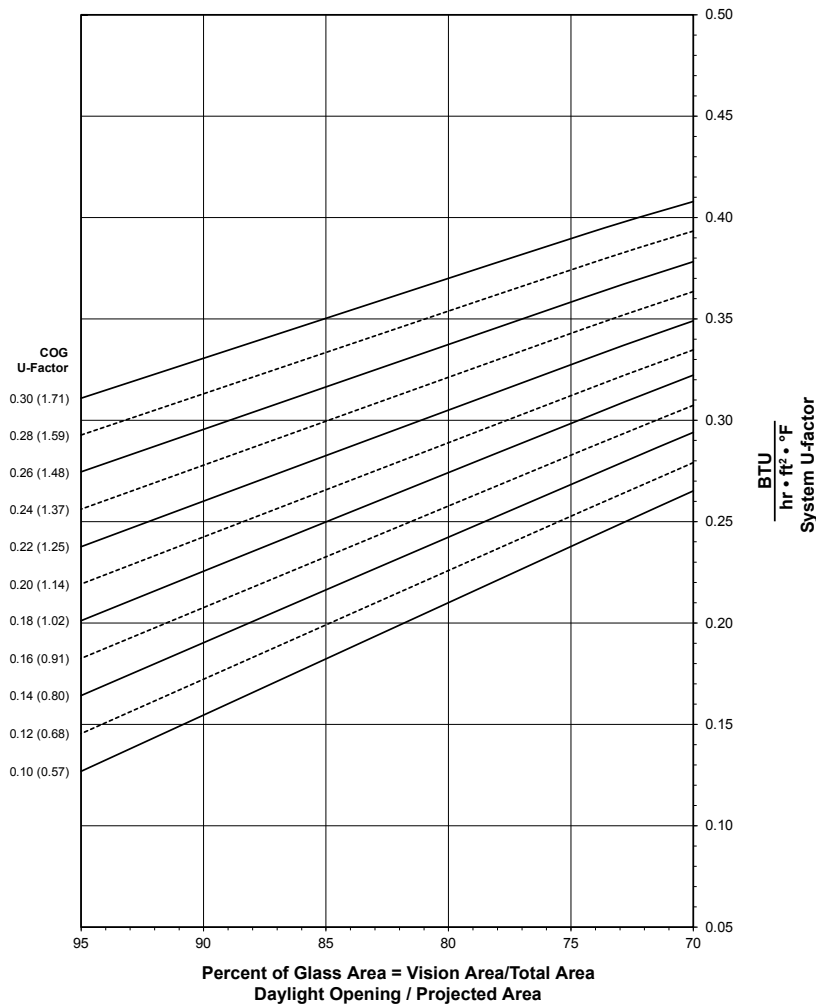

See Note, page 30.



AW (Deep) - Project-Out Window with 1-3/4" Glazing**Thermal Transmittance (BTU/hr • ft² • °F)**

Glass U-factor ^{a. b. c.}	Overall U-factor ^{d.}
0.30	0.39
0.28	0.38
0.26	0.36
0.24	0.35
0.22	0.33
0.20	0.31
0.18	0.30
0.16	0.29
0.14	0.27
0.12	0.26
0.10	0.24

^{a.}U-factor values are determined in accordance with NFRC 100.

^{b.}For glass values that are not listed, linear interpolation is permitted.

^{c.}Glass properties are based on center-of-glass values and are obtained from your glass supplier.

^{d.}Overall U-factor values are based on the standard NFRC specimen size of 1,500 mm wide by 600 mm high (59-1/6" by 23-5/8").

System Solar Heat Gain Coefficient (SHGC) - AW (Deep) - Project-Out Window with 1-3/4" Glazing

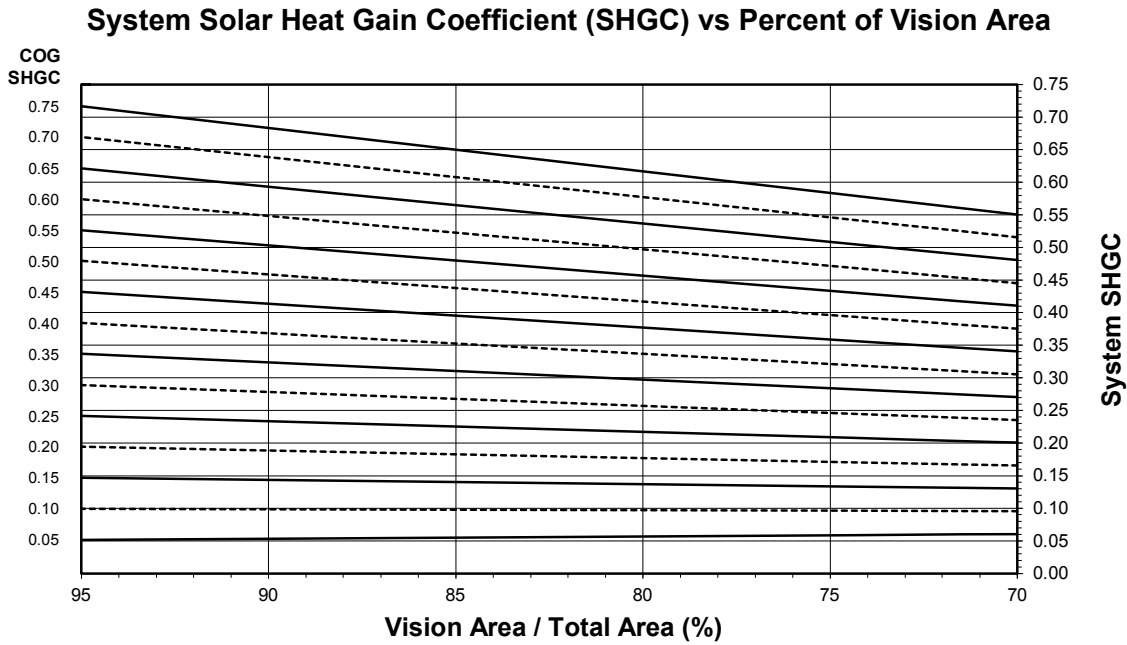

See [Note, page 30](#).

Solar Heat Gain Coefficient (SHGC) Matrix

Glass SHGC ^{a. b. c.}	Overall SHGC ^{d.}
0.75	0.58
0.70	0.54
0.65	0.51
0.60	0.47
0.55	0.43
0.50	0.39
0.45	0.36
0.40	0.32
0.35	0.28
0.30	0.24
0.25	0.21
0.20	0.17
0.15	0.13
0.10	0.10
0.05	0.06

^{a.} SHGC values are determined in accordance with NFRC 200.

^{b.} For glass values that are not listed, linear interpolation is permitted.

^{c.} Glass properties are based on center-of-glass values and are obtained from your glass supplier.

^{d.} Overall SHGC values are based on the standard NFRC specimen size of 1,500 mm wide by 600 mm high (59-1/6" by 23-5/8").



System Visible Transmittance (VT) - AW (Deep) - Project-Out Window with 1-3/4" Glazing

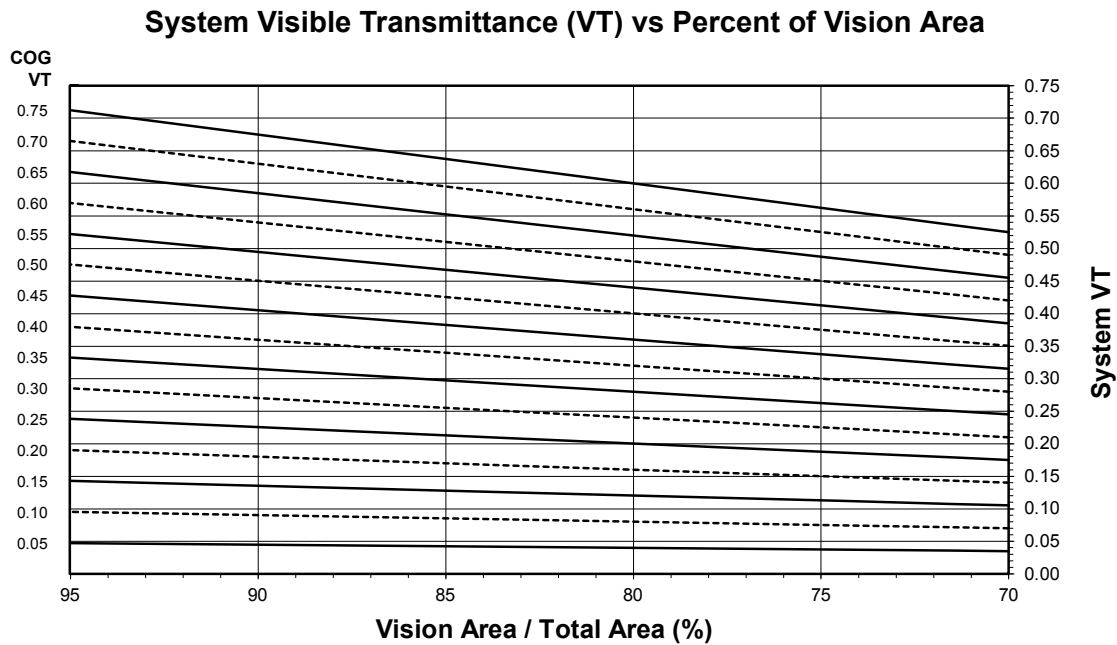

See [Note, page 30](#).

Visible Transmittance (VT)

Glass VT ^{a. b. c.}	Overall VT ^{d.}
0.75	0.56
0.70	0.52
0.65	0.48
0.60	0.45
0.55	0.41
0.50	0.37
0.45	0.33
0.40	0.30
0.35	0.26
0.30	0.22
0.25	0.19
0.20	0.15
0.15	0.11
0.10	0.07
0.05	0.04

^{a.}VT values are determined in accordance with NFRC 200.

^{b.}For glass values that are not listed, linear interpolation is permitted.

^{c.}Glass properties are based on center-of-glass values and are obtained from your glass supplier.

^{d.}Overall VT values are based on the standard NFRC specimen size of 1,500 mm wide by 600 mm high (59-1/6" by 23-5/8").

AW (Deep) - Outswing Casement Window with 1" Glazing (Warm-Edge Glazing Spacer)



NOTE

These notes apply to the charts for system U-factor, solar heat gain coefficient (SHGC), and visible transmittance (VT):

- Values in parentheses are metric.
- COG = Center of Glass
- Charts are generated per AAMA 507.
- For glass values that are not listed, linear interpolation is permitted.
- Glass properties are based on center-of-glass values and are obtained from your glass supplier.

System U-factor for Glass Area

System U-factor vs Percent of Glass Area

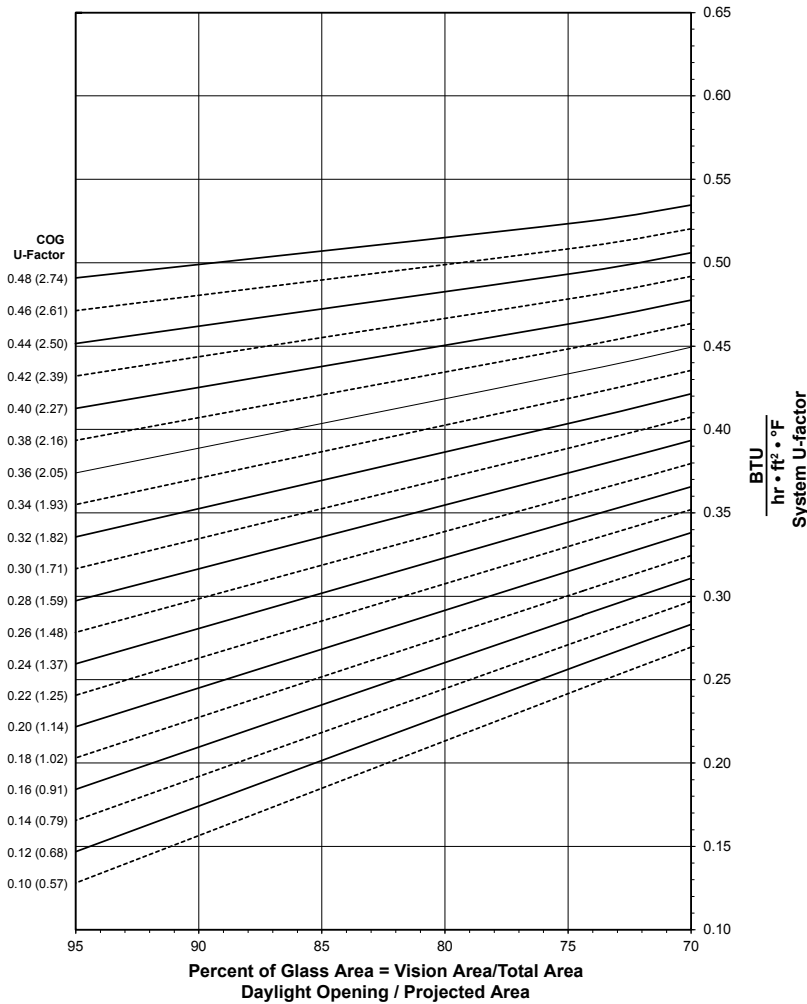

See Note, page 34.



AW (Deep) - Outswing Casement Window with 1" Glazing**Thermal Transmittance (BTU/hr • ft² • °F)**

Glass U-factor ^{a. b. c.}	Overall U-factor ^{d.}
0.48	0.52
0.46	0.51
0.44	0.49
0.42	0.48
0.40	0.46
0.38	0.45
0.36	0.44
0.34	0.42
0.32	0.41
0.30	0.39
0.28	0.38
0.26	0.36
0.24	0.35
0.22	0.33
0.20	0.32
0.18	0.30
0.16	0.29
0.14	0.27
0.12	0.26
0.10	0.24

^{a.}U-factor values are determined in accordance with NFRC 100.

^{b.}For glass values that are not listed, linear interpolation is permitted.

^{c.}Glass properties are based on center-of-glass values and are obtained from your glass supplier.

^{d.}Overall U-factor values are based on the standard NFRC specimen size of 1,500 mm wide by 600 mm high (59-1/6" by 23-5/8").

System Solar Heat Gain Coefficient (SHGC) - AW (Deep) - Outswing Casement Window with 1" Glazing

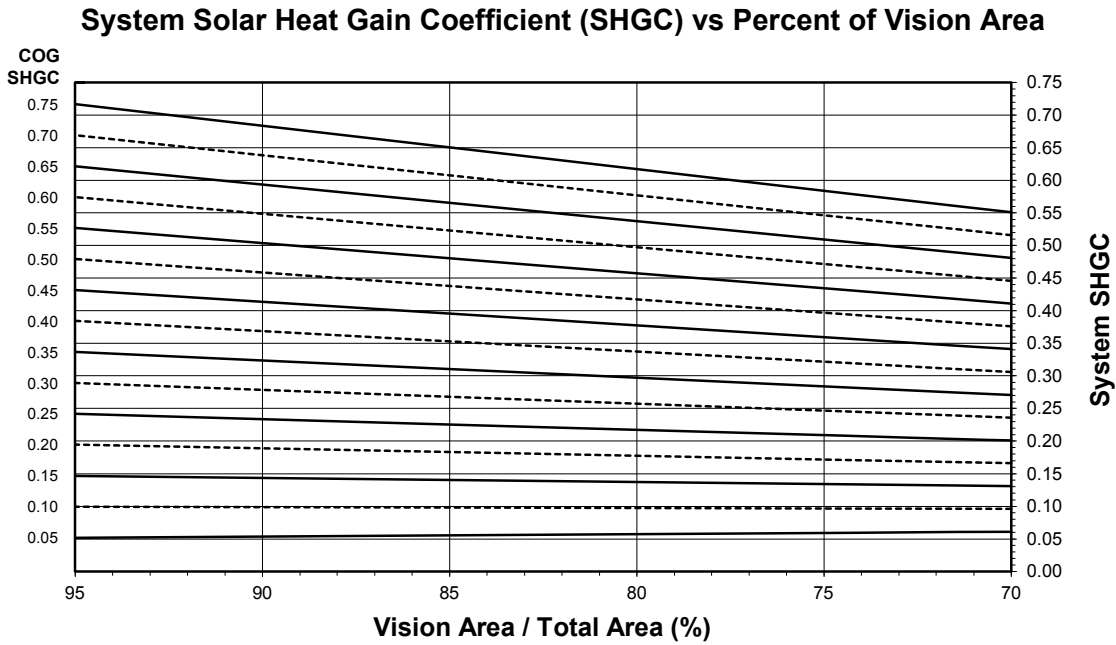

See [Note, page 34](#).

Solar Heat Gain Coefficient (SHGC) Matrix

Glass SHGC ^{a. b. c.}	Overall SHGC ^{d.}
0.75	0.58
0.70	0.54
0.65	0.51
0.60	0.47
0.55	0.43
0.50	0.39
0.45	0.36
0.40	0.32
0.35	0.28
0.30	0.25
0.25	0.21
0.20	0.17
0.15	0.13
0.10	0.10
0.05	0.06

^{a.} SHGC values are determined in accordance with NFRC 200.

^{b.} For glass values that are not listed, linear interpolation is permitted.

^{c.} Glass properties are based on center-of-glass values and are obtained from your glass supplier.

^{d.} Overall SHGC values are based on the standard NFRC specimen size of 1,500 mm wide by 600 mm high (59-1/6" by 23-5/8").



System Visible Transmittance (VT) - AW (Deep) - Outswing Casement Window with 1" Glazing

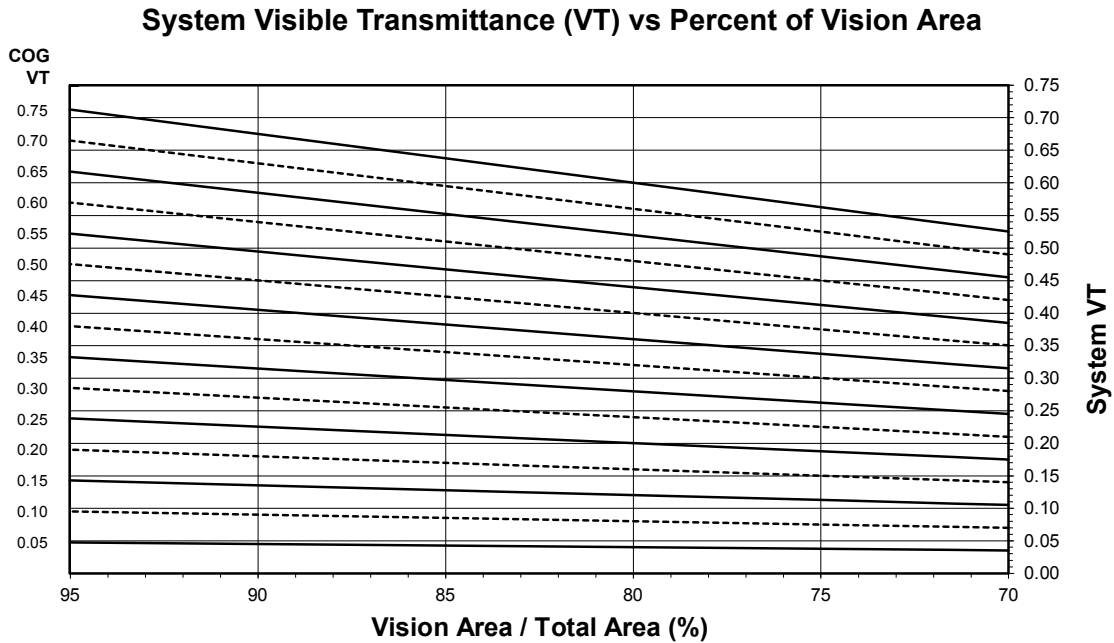

See [Note, page 34](#).

Visible Transmittance (VT)

Glass VT ^{a. b. c.}	Overall VT ^{d.}
0.75	0.56
0.70	0.52
0.65	0.48
0.60	0.45
0.55	0.41
0.50	0.37
0.45	0.33
0.40	0.30
0.35	0.26
0.30	0.22
0.25	0.19
0.20	0.15
0.15	0.11
0.10	0.07
0.05	0.04

^{a.}VT values are determined in accordance with NFRC 200.

^{b.}For glass values that are not listed, linear interpolation is permitted.

^{c.}Glass properties are based on center-of-glass values and are obtained from your glass supplier.

^{d.}Overall VT values are based on the standard NFRC specimen size of 1,500 mm wide by 600 mm high (59-1/6" by 23-5/8").

AW (Deep) - Outswing Casement Window with 1-3/4" Glazing (Warm-Edge Glazing Spacer)



NOTE

These notes apply to the charts for system U-factor, solar heat gain coefficient (SHGC), and visible transmittance (VT):

- Values in parentheses are metric.
- COG = Center of Glass
- Charts are generated per AAMA 507.
- For glass values that are not listed, linear interpolation is permitted.
- Glass properties are based on center-of-glass values and are obtained from your glass supplier.

System U-factor for Glass Area

System U-factor vs Percent of Glass Area

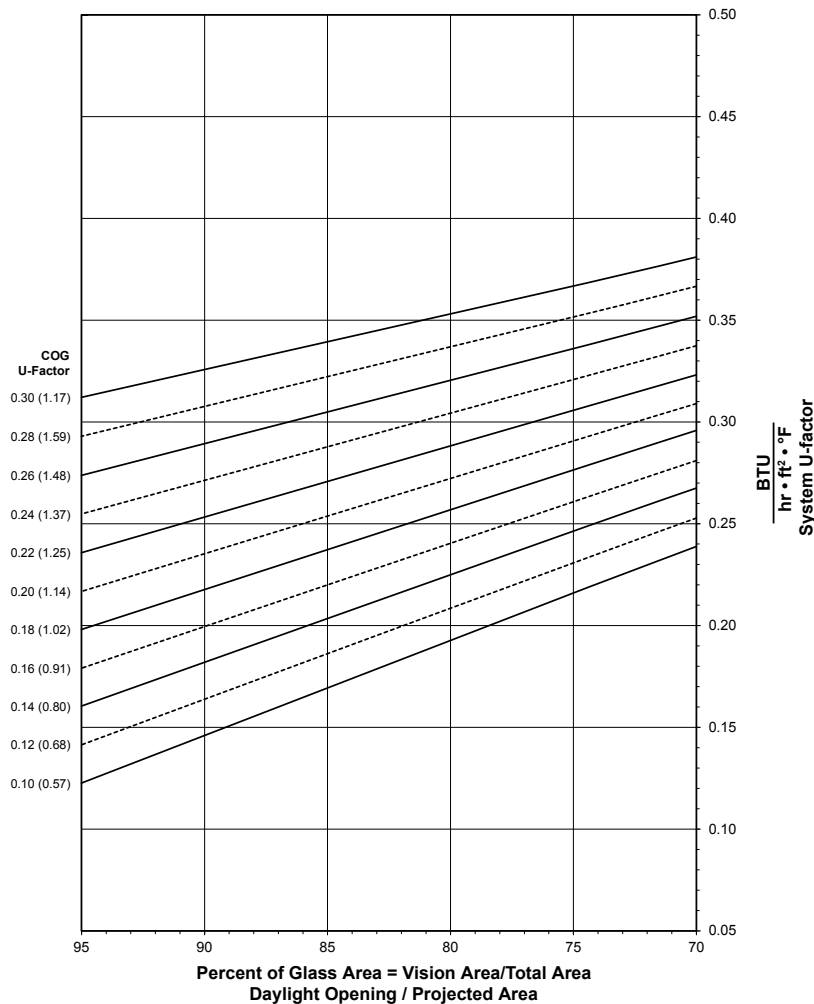

See Note, page 38.



AW (Deep) - Outswing Casement Window with 1-3/4" Glazing**Thermal Transmittance (BTU/hr • ft² • °F)**

Glass U-factor ^{a. b. c.}	Overall U-factor ^{d.}
0.30	0.37
0.28	0.35
0.26	0.34
0.24	0.32
0.22	0.31
0.20	0.29
0.18	0.28
0.16	0.26
0.14	0.25
0.12	0.23
0.10	0.22

^{a.}U-factor values are determined in accordance with NFRC 100.

^{b.}For glass values that are not listed, linear interpolation is permitted.

^{c.}Glass properties are based on center-of-glass values and are obtained from your glass supplier.

^{d.}Overall U-factor values are based on the standard NFRC specimen size of 1,500 mm wide by 600 mm high (59-1/6" by 23-5/8").

System Solar Heat Gain Coefficient (SHGC) - AW (Deep) - Outswing Casement Window with 1-3/4" Glazing

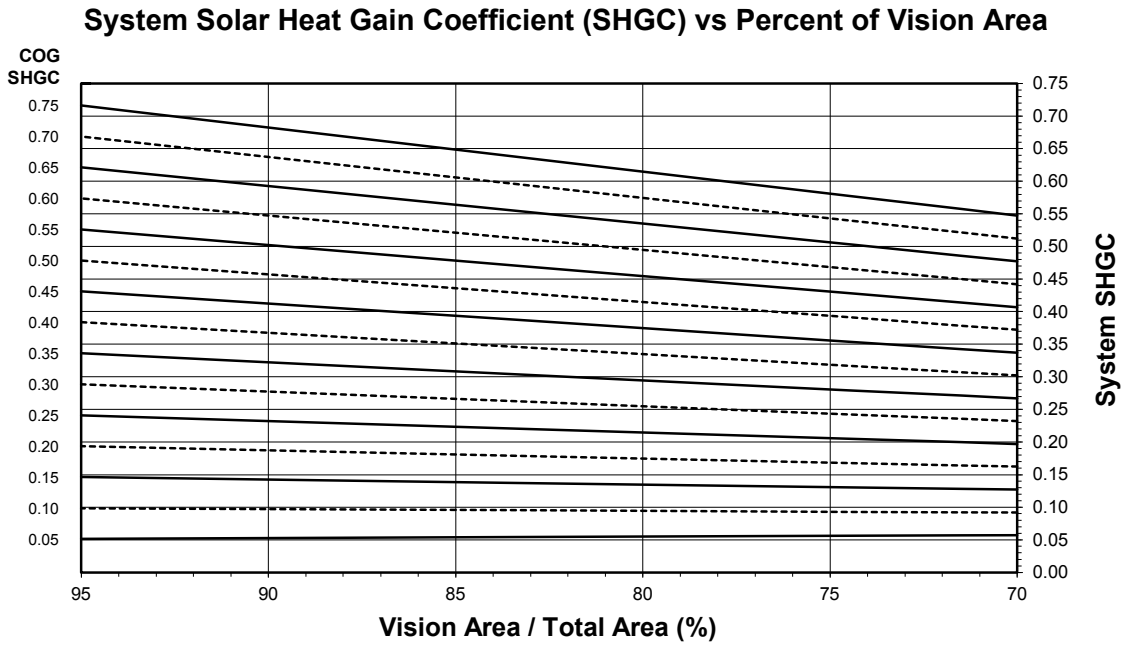

See [Note, page 38](#).

Solar Heat Gain Coefficient (SHGC) Matrix

Glass SHGC ^{a. b. c.}	Overall SHGC ^{d.}
0.75	0.58
0.70	0.54
0.65	0.50
0.60	0.47
0.55	0.43
0.50	0.39
0.45	0.35
0.40	0.32
0.35	0.28
0.30	0.24
0.25	0.20
0.20	0.17
0.15	0.13
0.10	0.09
0.05	0.06

^{a.} SHGC values are determined in accordance with NFRC 200.

^{b.} For glass values that are not listed, linear interpolation is permitted.

^{c.} Glass properties are based on center-of-glass values and are obtained from your glass supplier.

^{d.} Overall SHGC values are based on the standard NFRC specimen size of 1,500 mm wide by 600 mm high (59-1/6" by 23-5/8").



System Visible Transmittance (VT) - AW (Deep) - Outswing Casement Window with 1-3/4" Glazing

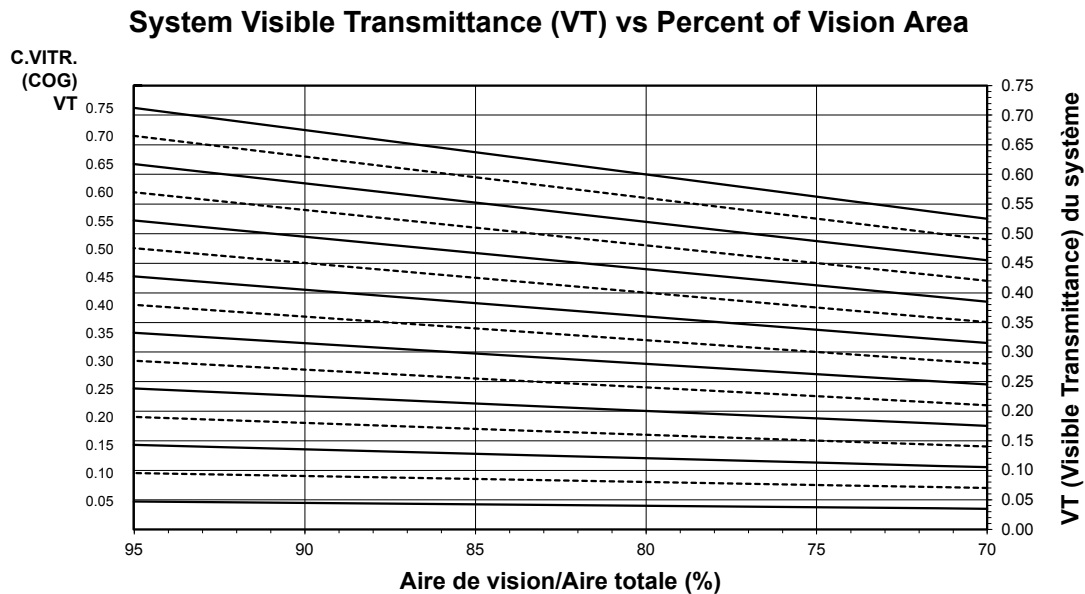

See [Note, page 38](#).

Visible Transmittance (VT)

Glass VT ^{a, b, c.}	Overall VT ^{d.}
0.75	0.56
0.70	0.52
0.65	0.48
0.60	0.45
0.55	0.41
0.50	0.37
0.45	0.33
0.40	0.30
0.35	0.26
0.30	0.22
0.25	0.19
0.20	0.15
0.15	0.11
0.10	0.07
0.05	0.04

^aVT values are determined in accordance with NFRC 200.

^bFor glass values that are not listed, linear interpolation is permitted.

^cGlass properties are based on center-of-glass values and are obtained from your glass supplier.

^dOverall VT values are based on the standard NFRC specimen size of 1,500 mm wide by 600 mm high (59-1/6" by 23-5/8").

AW (Deep) - Project-Out Window with 1" Glazing (Aluminum Glazing Spacer)



NOTE

These notes apply to the charts for system U-factor, solar heat gain coefficient (SHGC), and visible transmittance (VT):

- Values in parentheses are metric.
- COG = Center of Glass
- Charts are generated per AAMA 507.
- For glass values that are not listed, linear interpolation is permitted.
- Glass properties are based on center-of-glass values and are obtained from your glass supplier.

System U-factor for Glass Area

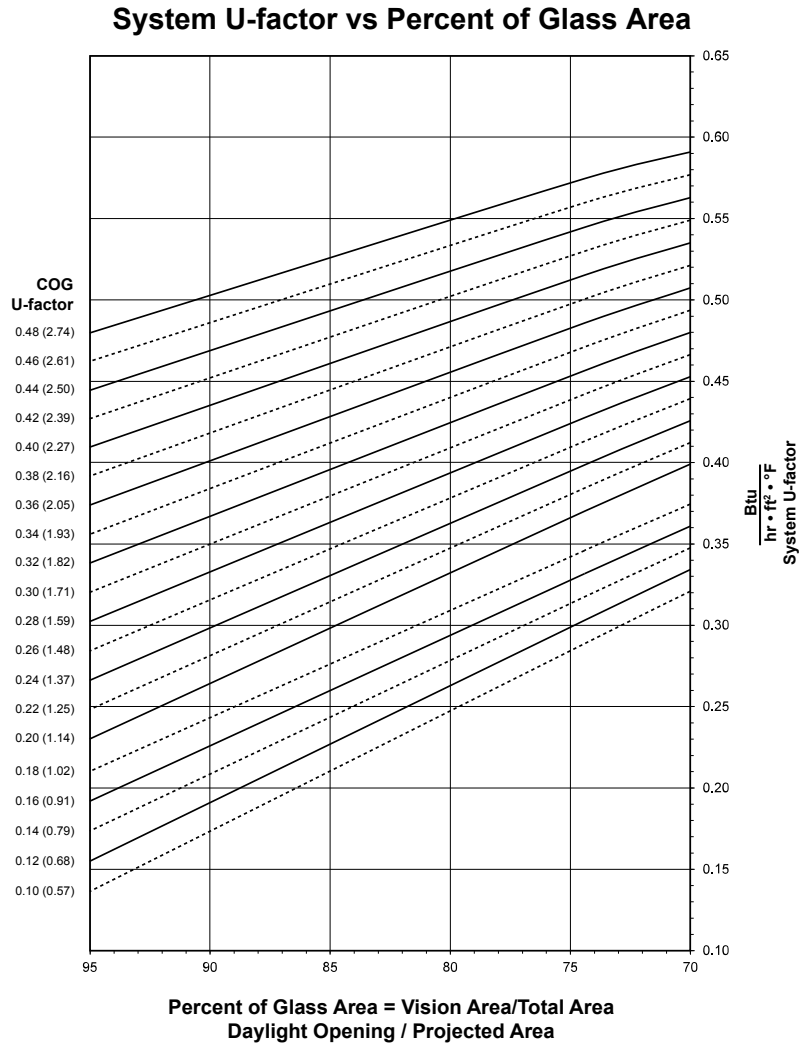

See Note, page 42.

AW (Deep) - Project-Out Window with 1" Glazing**Thermal Transmittance (BTU/hr • ft² • °F)**

Glass U-factor ^{a. b. c.}	Overall U-factor ^{d.}
0.48	0.57
0.46	0.56
0.44	0.54
0.42	0.53
0.40	0.52
0.38	0.50
0.36	0.49
0.34	0.47
0.32	0.46
0.30	0.44
0.28	0.43
0.26	0.41
0.24	0.40
0.22	0.38
0.20	0.37

^{a.}U-factor values are determined in accordance with NFRC 100.

^{b.}For glass values that are not listed, linear interpolation is permitted.

^{c.}Glass properties are based on center-of-glass values and are obtained from your glass supplier.

^{d.}Overall U-factor values are based on the standard NFRC specimen size of 1,500 mm wide by 600 mm high (59-1/6" by 23-5/8").

System Solar Heat Gain Coefficient (SHGC) - AW (Deep) - Project-Out Window with 1" Glazing

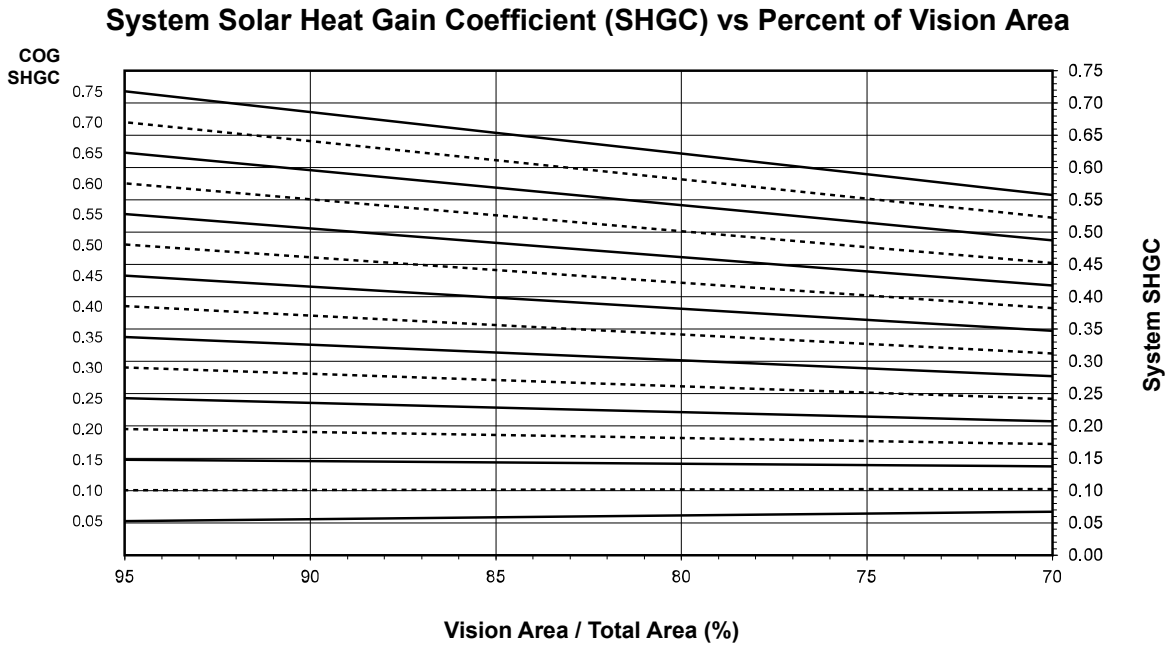

See [Note, page 42](#).

Solar Heat Gain Coefficient (SHGC) Matrix

Glass SHGC ^{a. b. c.}	Overall SHGC ^{d.}
0.75	0.59
0.70	0.55
0.65	0.51
0.60	0.47
0.55	0.44
0.50	0.40
0.45	0.36
0.40	0.33
0.35	0.29
0.30	0.25
0.25	0.21
0.20	0.18
0.15	0.14
0.10	0.10
0.05	0.06

^{a.} SHGC values are determined in accordance with NFRC 200.

^{b.} For glass values that are not listed, linear interpolation is permitted.

^{c.} Glass properties are based on center-of-glass values and are obtained from your glass supplier.

^{d.} Overall SHGC values are based on the standard NFRC specimen size of 1,500 mm wide by 600 mm high (59-1/8" by 23-5/8").



System Visible Transmittance (VT) - AW (Deep) - Project-Out Window with 1" Glazing

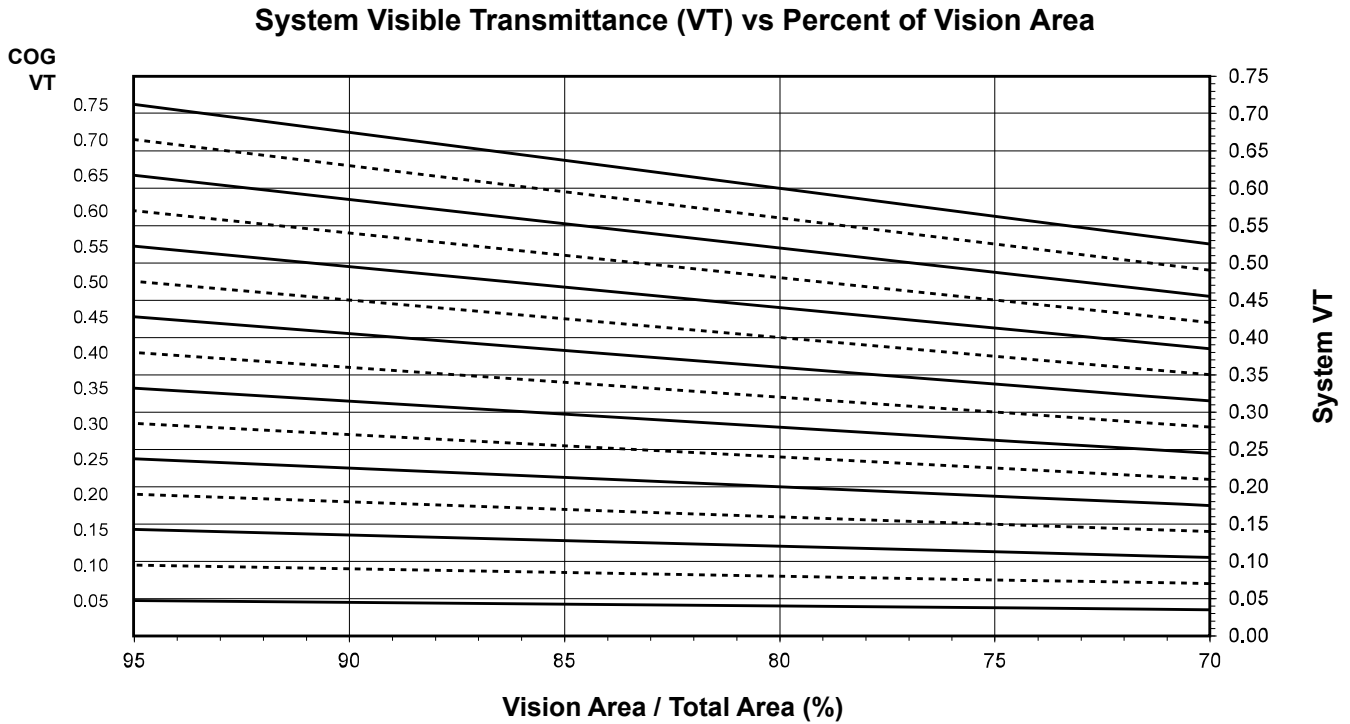

See [Note, page 42](#).

Visible Transmittance (VT)

Glass VT ^{a. b. c.}	Overall VT ^{d.}
0.75	0.56
0.70	0.52
0.65	0.48
0.60	0.45
0.55	0.41
0.50	0.37
0.45	0.33
0.40	0.30
0.35	0.26
0.30	0.22
0.25	0.19
0.20	0.15
0.15	0.11
0.10	0.07
0.05	0.04

^{a.}VT values are determined in accordance with NFRC 200.

^{b.}For glass values that are not listed, linear interpolation is permitted.

^{c.}Glass properties are based on center-of-glass values and are obtained from your glass supplier.

^{d.}Overall VT values are based on the standard NFRC specimen size of 1,500 mm wide by 600 mm high (59-1/6" by 23-5/8").

AW (Deep) - Project-Out Window with 1-3/4" Glazing (Aluminum Glazing Spacer)



NOTE

These notes apply to the charts for system U-factor, solar heat gain coefficient (SHGC), and visible transmittance (VT):

- Values in parentheses are metric.
- COG = Center of Glass
- Charts are generated per AAMA 507.
- For glass values that are not listed, linear interpolation is permitted.
- Glass properties are based on center-of-glass values and are obtained from your glass supplier.

System U-factor for Glass Area

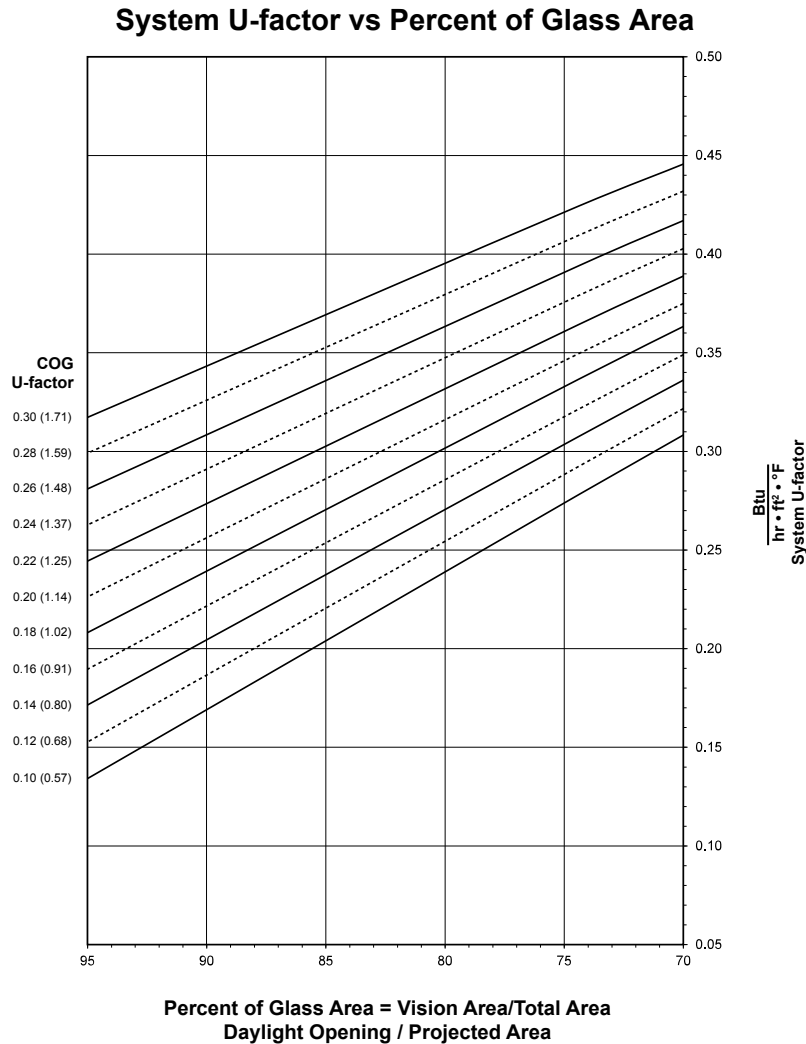

See Note, page 46.



AW (Deep) - Project-Out Window with 1-3/4" Glazing**Thermal Transmittance (BTU/hr • ft² • °F)**

Glass U-factor ^{a. b. c.}	Overall U-factor ^{d.}
0.30	0.42
0.28	0.41
0.26	0.39
0.24	0.38
0.22	0.36
0.20	0.35
0.18	0.34
0.16	0.32
0.14	0.31
0.12	0.29
0.10	0.28

^{a.}U-factor values are determined in accordance with NFRC 100.

^{b.}For glass values that are not listed, linear interpolation is permitted.

^{c.}Glass properties are based on center-of-glass values and are obtained from your glass supplier.

^{d.}Overall U-factor values are based on the standard NFRC specimen size of 1,500 mm wide by 600 mm high (59-1/6" by 23-5/8").

System Solar Heat Gain Coefficient (SHGC) - AW (Deep) - Project-Out Window with 1-3/4" Glazing

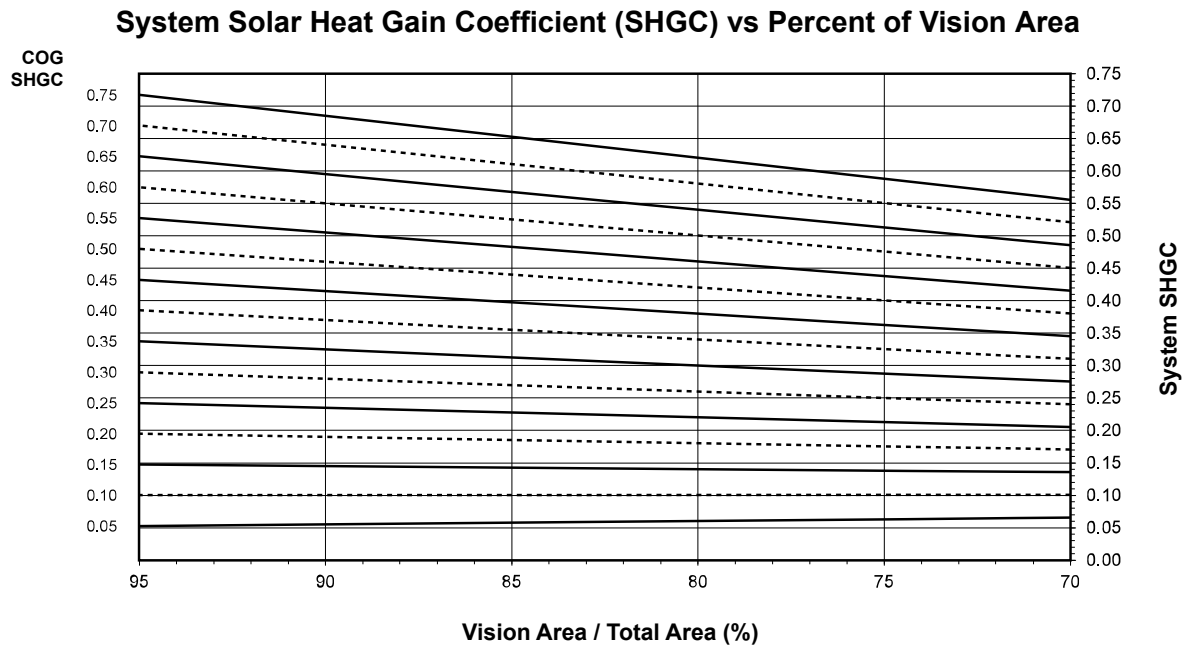

See [Note, page 46](#).

Solar Heat Gain Coefficient (SHGC) Matrix

Glass SHGC ^{a. b. c.}	Overall SHGC ^{d.}
0.75	0.58
0.70	0.55
0.65	0.51
0.60	0.47
0.55	0.44
0.50	0.40
0.45	0.36
0.40	0.32
0.35	0.29
0.30	0.25
0.25	0.21
0.20	0.17
0.15	0.14
0.10	0.10
0.05	0.06

^{a.} SHGC values are determined in accordance with NFRC 200.

^{b.} For glass values that are not listed, linear interpolation is permitted.

^{c.} Glass properties are based on center-of-glass values and are obtained from your glass supplier.

^{d.} Overall SHGC values are based on the standard NFRC specimen size of 1,500 mm wide by 600 mm high (59-1/6" by 23-5/8").



System Visible Transmittance (VT) - AW (Deep) - Project-Out Window with 1-3/4" Glazing

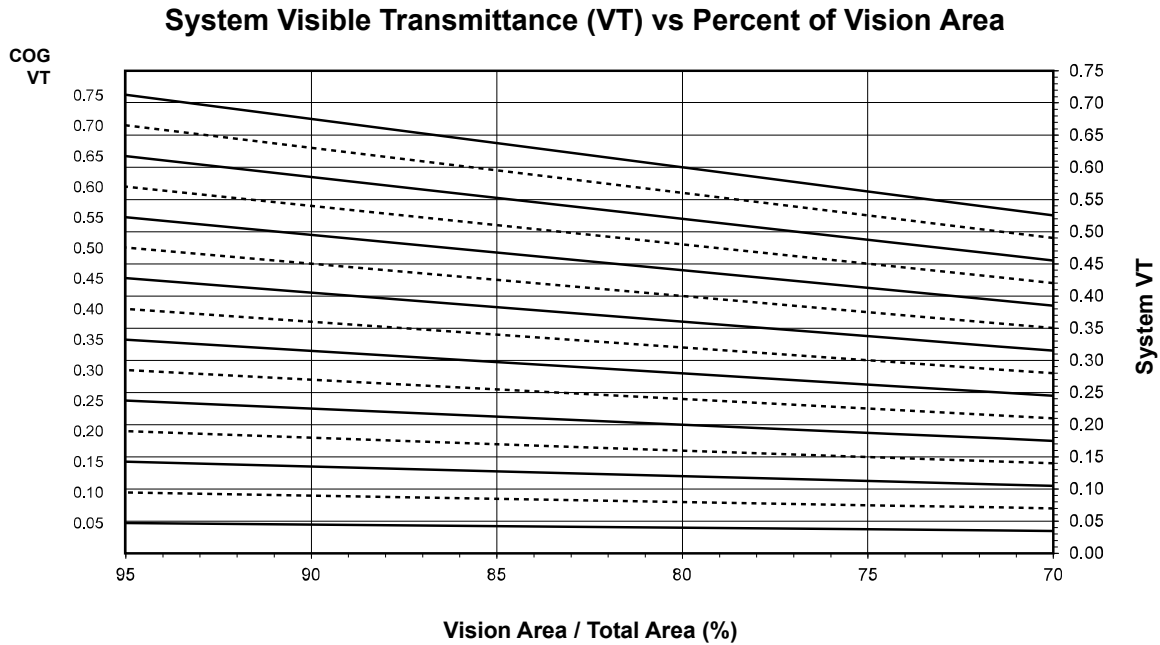

See [Note, page 46](#).

Visible Transmittance (VT)

Glass VT ^{a. b. c.}	Overall VT ^{d.}
0.75	0.56
0.70	0.52
0.65	0.48
0.60	0.45
0.55	0.41
0.50	0.37
0.45	0.33
0.40	0.30
0.35	0.26
0.30	0.22
0.25	0.19
0.20	0.15
0.15	0.11
0.10	0.07
0.05	0.04

^{a.}VT values are determined in accordance with NFRC 200.

^{b.}For glass values that are not listed, linear interpolation is permitted.

^{c.}Glass properties are based on center-of-glass values and are obtained from your glass supplier.

^{d.}Overall VT values are based on the standard NFRC specimen size of 1,500 mm wide by 600 mm high (59-1/6" by 23-5/8").

AW (Deep) - Outswing Casement Window with 1" Glazing (Aluminum Glazing Spacer)



NOTE

These notes apply to the charts for system U-factor, solar heat gain coefficient (SHGC), and visible transmittance (VT):

- Values in parentheses are metric.
- COG = Center of Glass
- Charts are generated per AAMA 507.
- For glass values that are not listed, linear interpolation is permitted.
- Glass properties are based on center-of-glass values and are obtained from your glass supplier.

System U-factor for Glass Area

System U-factor vs Percent of Glass Area

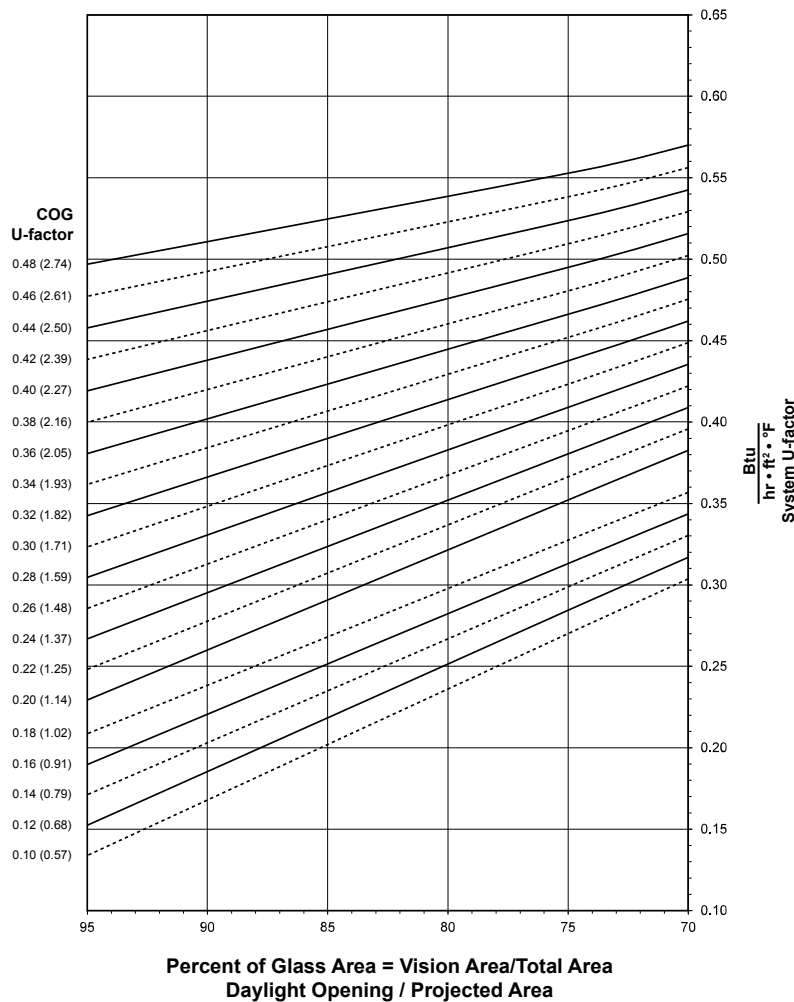

See Note, page 50.



AW (Deep) - Outswing Casement Window with 1" Glazing**Thermal Transmittance (BTU/hr • ft² • °F)**

Glass U-factor ^{a. b. c.}	Overall U-factor ^{d.}
0.48	0.55
0.46	0.54
0.44	0.53
0.42	0.51
0.40	0.50
0.38	0.48
0.36	0.47
0.34	0.45
0.32	0.44
0.30	0.43
0.28	0.41
0.26	0.40
0.24	0.38
0.22	0.37
0.20	0.36
0.18	0.33
0.16	0.32
0.14	0.30
0.12	0.29
0.10	0.27

^{a.}U-factor values are determined in accordance with NFRC 100.

^{b.}For glass values that are not listed, linear interpolation is permitted.

^{c.}Glass properties are based on center-of-glass values and are obtained from your glass supplier.

^{d.}Overall U-factor values are based on the standard NFRC specimen size of 1,500 mm wide by 600 mm high (59-1/6" by 23-5/8").

System Solar Heat Gain Coefficient (SHGC) - AW (Deep) - Outswing Casement Window with 1" Glazing

System Solar Heat Gain Coefficient (SHGC) vs Percent of Vision Area

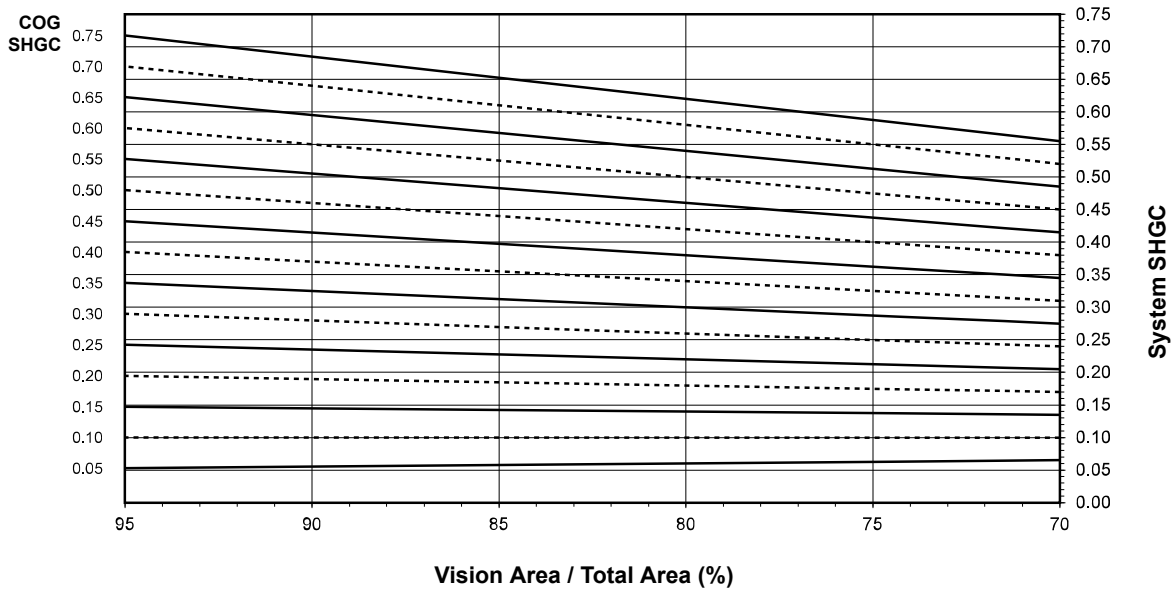

See [Note, page 50](#).

Solar Heat Gain Coefficient (SHGC) Matrix

Glass SHGC ^{a. b. c.}	Overall SHGC ^{d.}
0.75	0.58
0.70	0.55
0.65	0.51
0.60	0.47
0.55	0.43
0.50	0.40
0.45	0.36
0.40	0.32
0.35	0.29
0.30	0.25
0.25	0.21
0.20	0.17
0.15	0.14
0.10	0.10
0.05	0.06

^{a.} SHGC values are determined in accordance with NFRC 200.

^{b.} For glass values that are not listed, linear interpolation is permitted.

^{c.} Glass properties are based on center-of-glass values and are obtained from your glass supplier.

^{d.} Overall SHGC values are based on the standard NFRC specimen size of 1,500 mm wide by 600 mm high (59-1/8" by 23-5/8").

System Visible Transmittance (VT) - AW (Deep) - Outswing Casement Window with 1" Glazing

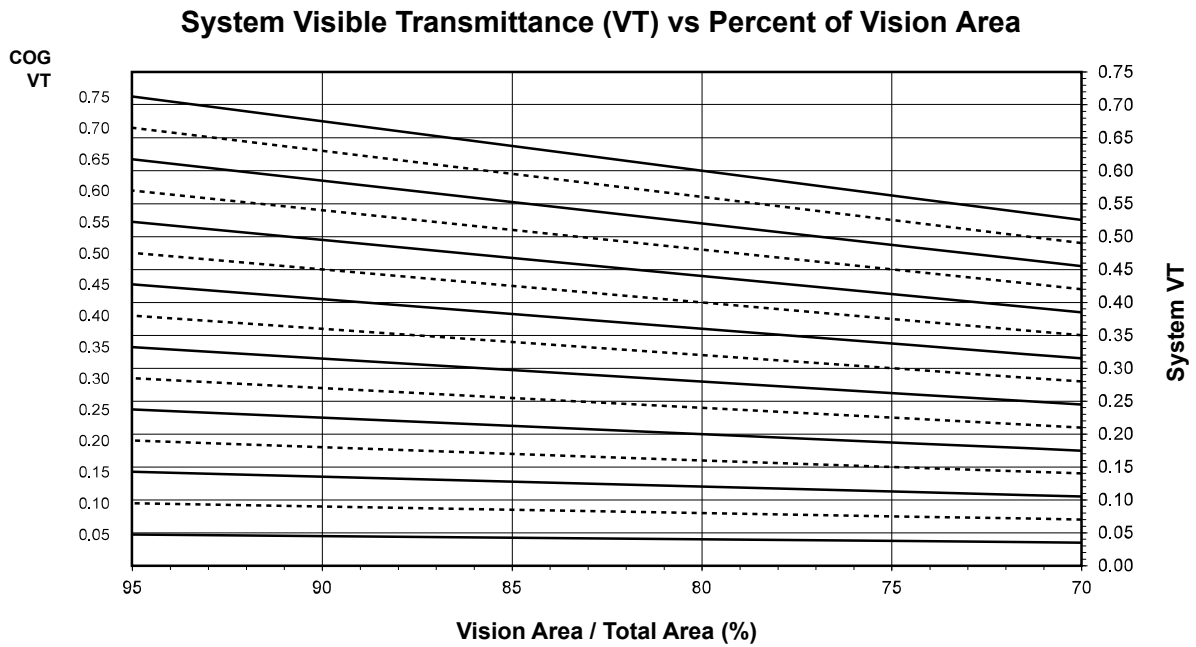

See [Note, page 50](#).

Visible Transmittance (VT)

Glass VT ^{a. b. c.}	Overall VT ^{d.}
0.75	0.56
0.70	0.52
0.65	0.48
0.60	0.45
0.55	0.41
0.50	0.37
0.45	0.33
0.40	0.30
0.35	0.26
0.30	0.22
0.25	0.19
0.20	0.15
0.15	0.11
0.10	0.07
0.05	0.04

^{a.}VT values are determined in accordance with NFRC 200.

^{b.}For glass values that are not listed, linear interpolation is permitted.

^{c.}Glass properties are based on center-of-glass values and are obtained from your glass supplier.

^{d.}Overall VT values are based on the standard NFRC specimen size of 1,500 mm wide by 600 mm high (59-1/6" by 23-5/8").

AW (Deep) - Outswing Casement Window with 1-3/4" Glazing (Aluminum Glazing Spacer)



NOTE

These notes apply to the charts for system U-factor, solar heat gain coefficient (SHGC), and visible transmittance (VT):

- Values in parentheses are metric.
- COG = Center of Glass
- Charts are generated per AAMA 507.
- For glass values that are not listed, linear interpolation is permitted.
- Glass properties are based on center-of-glass values and are obtained from your glass supplier.

System U-factor for Glass Area

System U-factor vs Percent of Glass Area

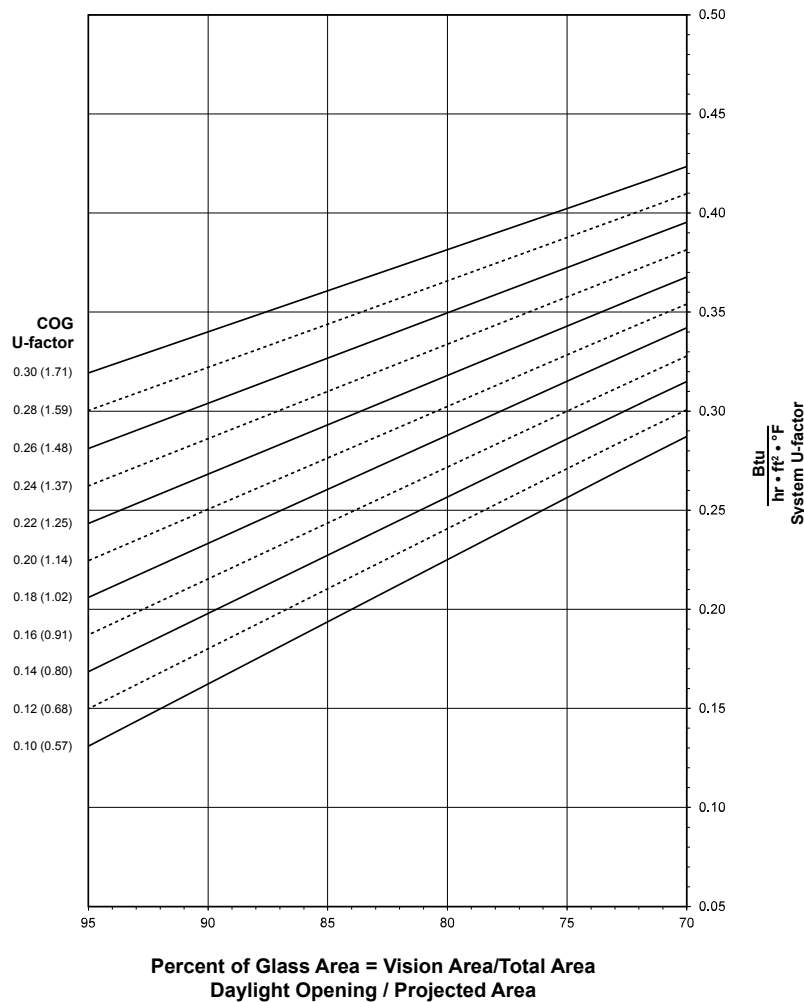

See Note, page 54.



AW (Deep) - Outswing Casement Window with 1-3/4" Glazing**Thermal Transmittance (BTU/hr • ft² • °F)**

Glass U-factor ^{a. b. c.}	Overall U-factor ^{d.}
0.30	0.40
0.28	0.39
0.26	0.38
0.24	0.36
0.22	0.35
0.20	0.33
0.18	0.32
0.16	0.30
0.14	0.29
0.12	0.27
0.10	0.26

^{a.}U-factor values are determined in accordance with NFRC 100.

^{b.}For glass values that are not listed, linear interpolation is permitted.

^{c.}Glass properties are based on center-of-glass values and are obtained from your glass supplier.

^{d.}Overall U-factor values are based on the standard NFRC specimen size of 1,500 mm wide by 600 mm high (59-1/6" by 23-5/8").

System Solar Heat Gain Coefficient (SHGC) - AW (Deep) - Outswing Casement Window with 1-3/4" Glazing

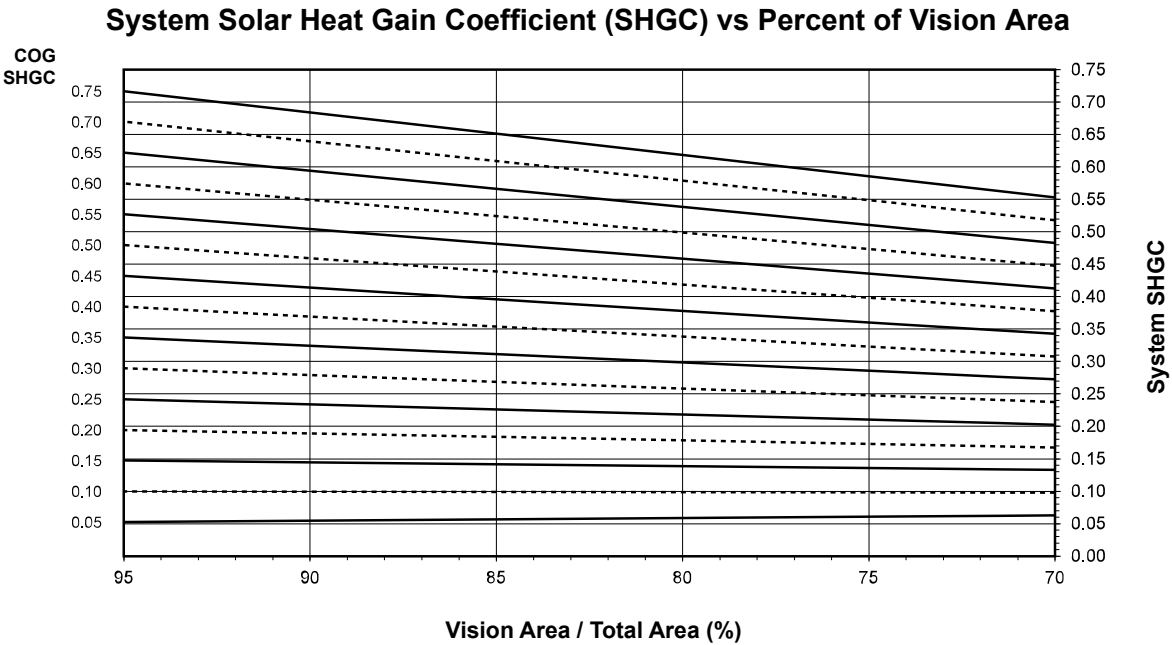

See [Note, page 54](#).

Solar Heat Gain Coefficient (SHGC) Matrix

Glass SHGC ^{a. b. c.}	Overall SHGC ^{d.}
0.75	0.58
0.70	0.54
0.65	0.51
0.60	0.47
0.55	0.43
0.50	0.40
0.45	0.36
0.40	0.32
0.35	0.28
0.30	0.25
0.25	0.21
0.20	0.17
0.15	0.14
0.10	0.10
0.05	0.06

^{a.} SHGC values are determined in accordance with NFRC 200.

^{b.} For glass values that are not listed, linear interpolation is permitted.

^{c.} Glass properties are based on center-of-glass values and are obtained from your glass supplier.

^{d.} Overall SHGC values are based on the standard NFRC specimen size of 1,500 mm wide by 600 mm high (59-1/6" by 23-5/8").



System Visible Transmittance (VT) - AW (Deep) - Outswing Casement Window with 1-3/4" Glazing

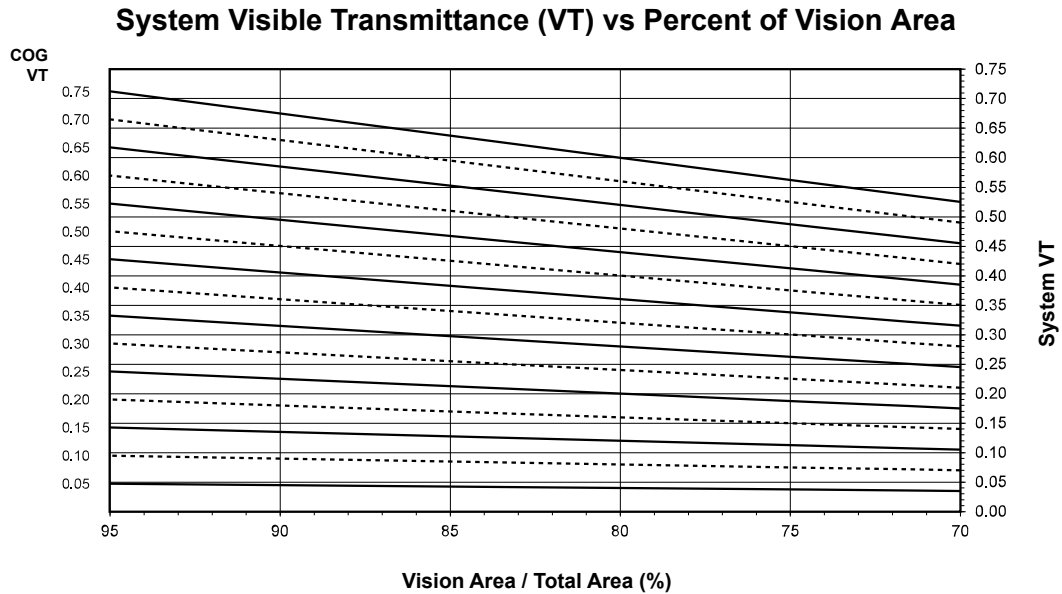

See [Note, page 54](#).

Visible Transmittance (VT)

Glass VT ^{a. b. c.}	Overall VT ^{d.}
0.75	0.56
0.70	0.52
0.65	0.48
0.60	0.45
0.55	0.41
0.50	0.37
0.45	0.33
0.40	0.30
0.35	0.26
0.30	0.22
0.25	0.19
0.20	0.15
0.15	0.11
0.10	0.07
0.05	0.04

^aVT values are determined in accordance with NFRC 200.

^bFor glass values that are not listed, linear interpolation is permitted.

^cGlass properties are based on center-of-glass values and are obtained from your glass supplier.

^dOverall VT values are based on the standard NFRC specimen size of 1,500 mm wide by 600 mm high (59-1/8" by 23-5/8").

CW (Shallow) - Project-Out Window with 1" Glazing (Aluminum Glazing Spacer)



NOTE

These notes apply to the charts for system U-factor, solar heat gain coefficient (SHGC), and visible transmittance (VT):

- Values in parentheses are metric.
- COG = Center of Glass
- Charts are generated per AAMA 507.
- For glass values that are not listed, linear interpolation is permitted.
- Glass properties are based on center-of-glass values and are obtained from your glass supplier.

System U-factor for Glass Area

System U-factor vs Percent of Glass Area

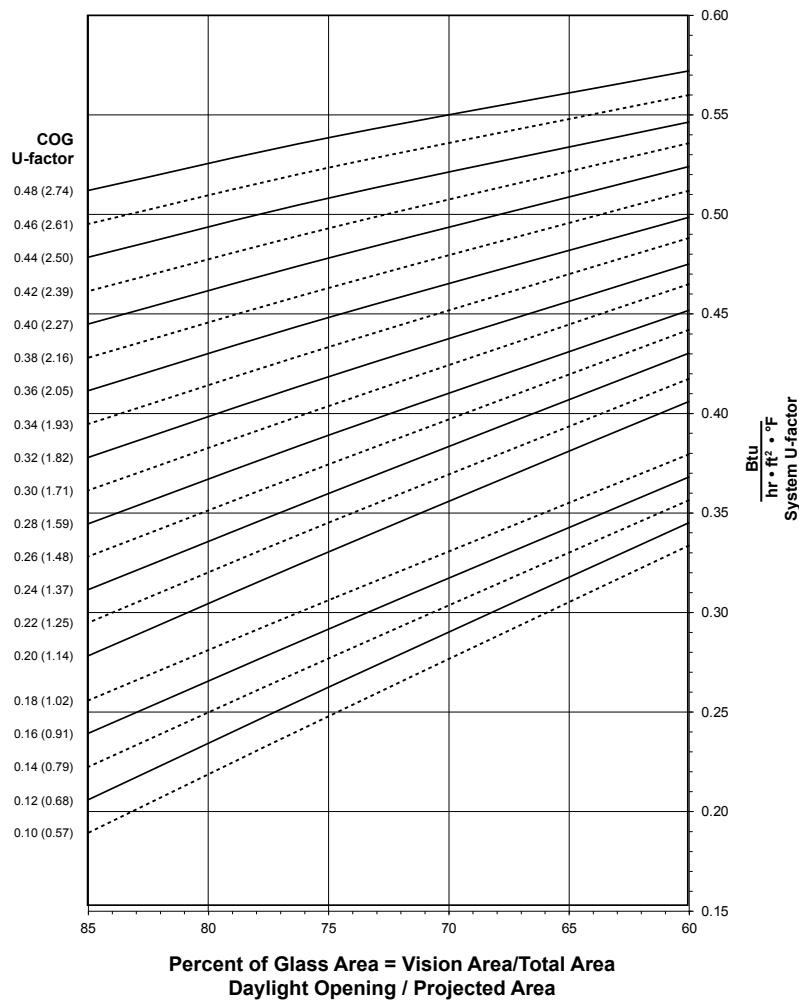

See Note, page 58.



CW (Shallow) - Project-Out Window with 1" Glazing**Thermal Transmittance (BTU/hr • ft² • °F)**

Glass U-factor ^{a. b. c.}	Overall U-factor ^{d.}
0.48	0.54
0.46	0.52
0.44	0.51
0.42	0.49
0.40	0.48
0.38	0.46
0.36	0.45
0.34	0.43
0.32	0.42
0.30	0.40
0.28	0.39
0.26	0.38
0.24	0.36
0.22	0.35
0.20	0.33
0.18	0.31
0.16	0.29
0.14	0.28
0.12	0.26
0.10	0.25

^{a.}U-factor values are determined in accordance with NFRC 100.

^{b.}For glass values that are not listed, linear interpolation is permitted.

^{c.}Glass properties are based on center-of-glass values and are obtained from your glass supplier.

^{d.}Overall U-factor values are based on the standard NFRC specimen size of 1,500 mm wide by 600 mm high (59-1/6" by 23-5/8").

System Solar Heat Gain Coefficient (SHGC) - CW (Shallow) - Project-Out Window with 1" Glazing

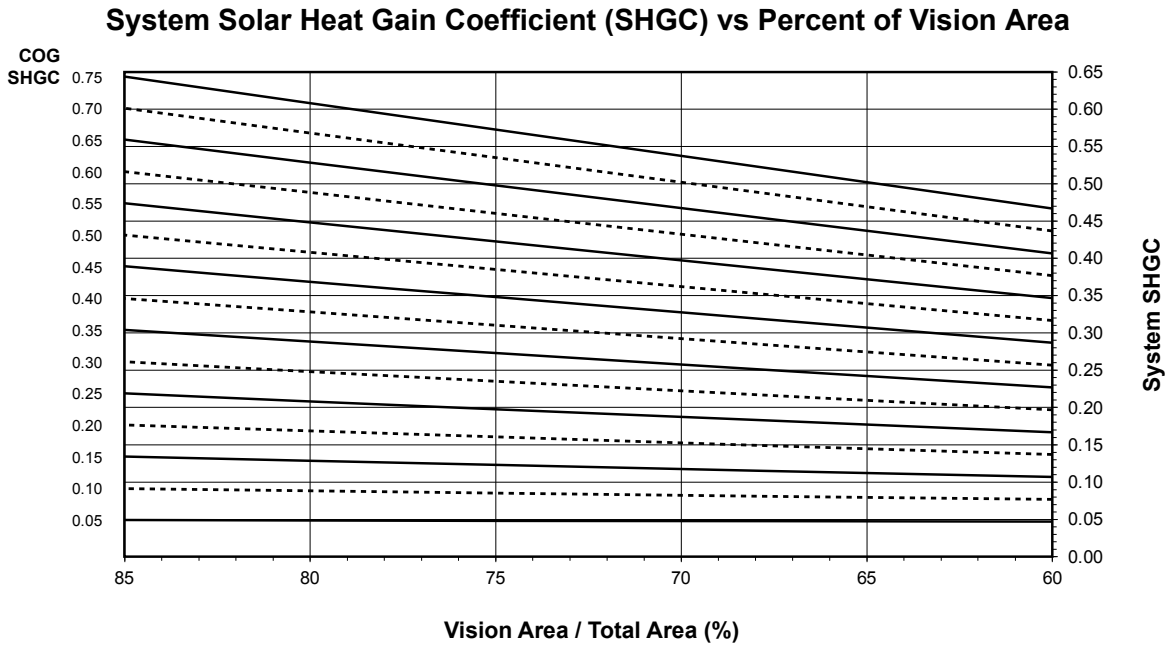

See [Note, page 58](#).

Solar Heat Gain Coefficient (SHGC) Matrix

Glass SHGC ^{a. b. c.}	Overall SHGC ^{d.}
0.75	0.57
0.70	0.53
0.65	0.50
0.60	0.46
0.55	0.42
0.50	0.38
0.45	0.35
0.40	0.31
0.35	0.27
0.30	0.23
0.25	0.20
0.20	0.16
0.15	0.12
0.10	0.09
0.05	0.05

^{a.} SHGC values are determined in accordance with NFRC 200.

^{b.} For glass values that are not listed, linear interpolation is permitted.

^{c.} Glass properties are based on center-of-glass values and are obtained from your glass supplier.

^{d.} Overall SHGC values are based on the standard NFRC specimen size of 1,500 mm wide by 600 mm high (59-1/6" by 23-5/8").

System Visible Transmittance (VT) - CW (Shallow) - Project-Out Window with 1" Glazing

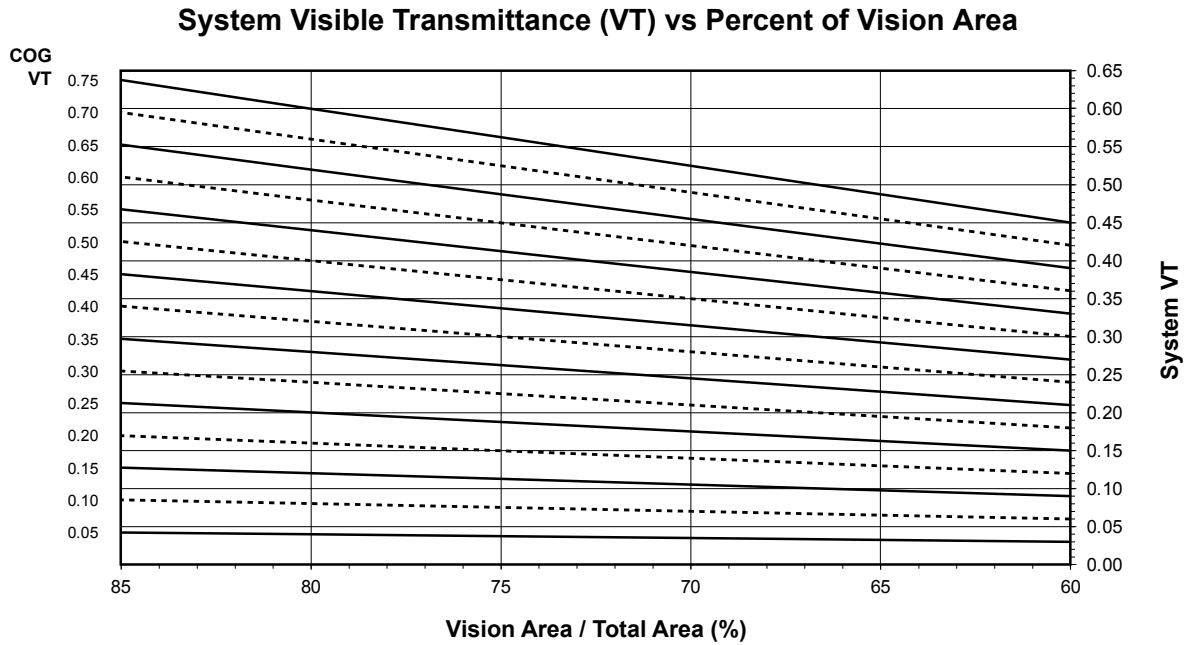

See [Note, page 58](#).

Visible Transmittance (VT)

Glass VT ^{a. b. c.}	Overall VT ^{d.}
0.75	0.56
0.70	0.52
0.65	0.49
0.60	0.45
0.55	0.41
0.50	0.37
0.45	0.34
0.40	0.30
0.35	0.26
0.30	0.22
0.25	0.19
0.20	0.15
0.15	0.11
0.10	0.07
0.05	0.04

^{a.}VT values are determined in accordance with NFRC 200.

^{b.}For glass values that are not listed, linear interpolation is permitted.

^{c.}Glass properties are based on center-of-glass values and are obtained from your glass supplier.

^{d.}Overall VT values are based on the standard NFRC specimen size of 1,500 mm wide by 600 mm high (59-1/6" by 23-5/8").

CW (Shallow) - Project-Out Window with 1-3/4" Glazing (Aluminum Glazing Spacer)



NOTE

These notes apply to the charts for system U-factor, solar heat gain coefficient (SHGC), and visible transmittance (VT):

- Values in parentheses are metric.
- COG = Center of Glass
- Charts are generated per AAMA 507.
- For glass values that are not listed, linear interpolation is permitted.
- Glass properties are based on center-of-glass values and are obtained from your glass supplier.

System U-factor for Glass Area

System U-factor vs Percent of Glass Area

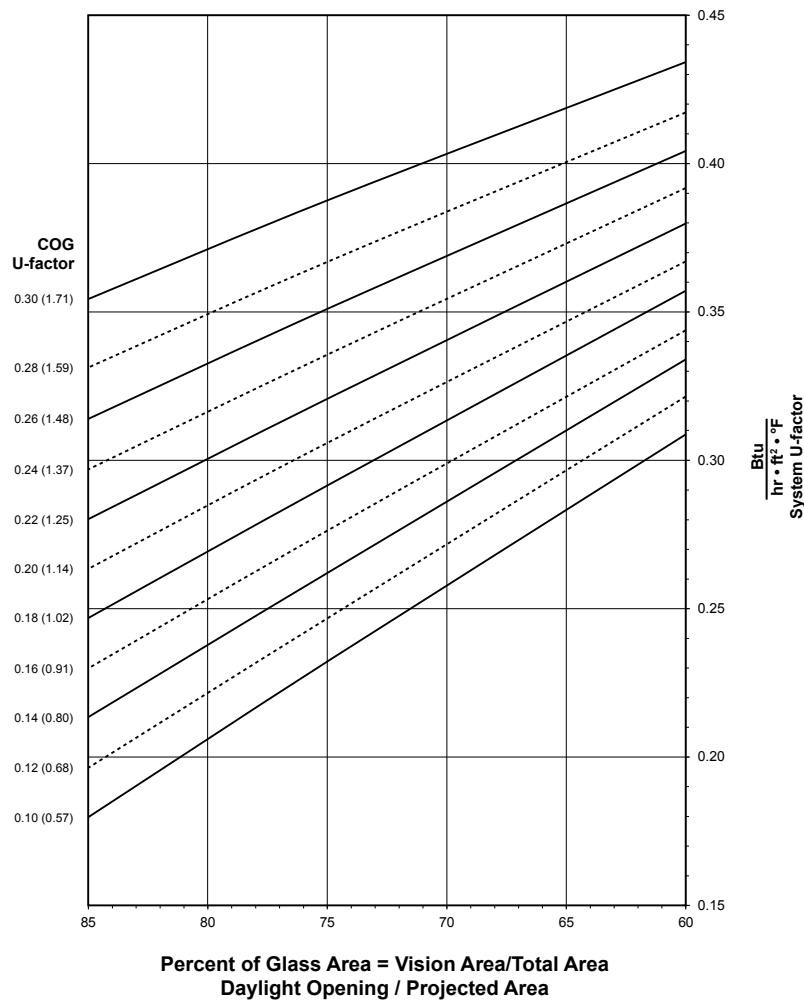

See Note, page 62.



CW (Shallow) - Project-Out Window with 1-3/4" Glazing**Thermal Transmittance (BTU/hr • ft² • °F)**

Glass U-factor ^{a. b. c.}	Overall U-factor ^{d.}
0.31	0.39
0.28	0.37
0.26	0.35
0.24	0.34
0.22	0.32
0.20	0.31
0.18	0.29
0.16	0.28
0.14	0.26
0.12	0.25
0.10	0.23

^{a.}U-factor values are determined in accordance with NFRC 100.

^{b.}For glass values that are not listed, linear interpolation is permitted.

^{c.}Glass properties are based on center-of-glass values and are obtained from your glass supplier.

^{d.}Overall U-factor values are based on the standard NFRC specimen size of 1,500 mm wide by 600 mm high (59-1/6" by 23-5/8").

System Solar Heat Gain Coefficient (SHGC) - CW (Shallow) - Project-Out Window with 1-3/4" Glazing

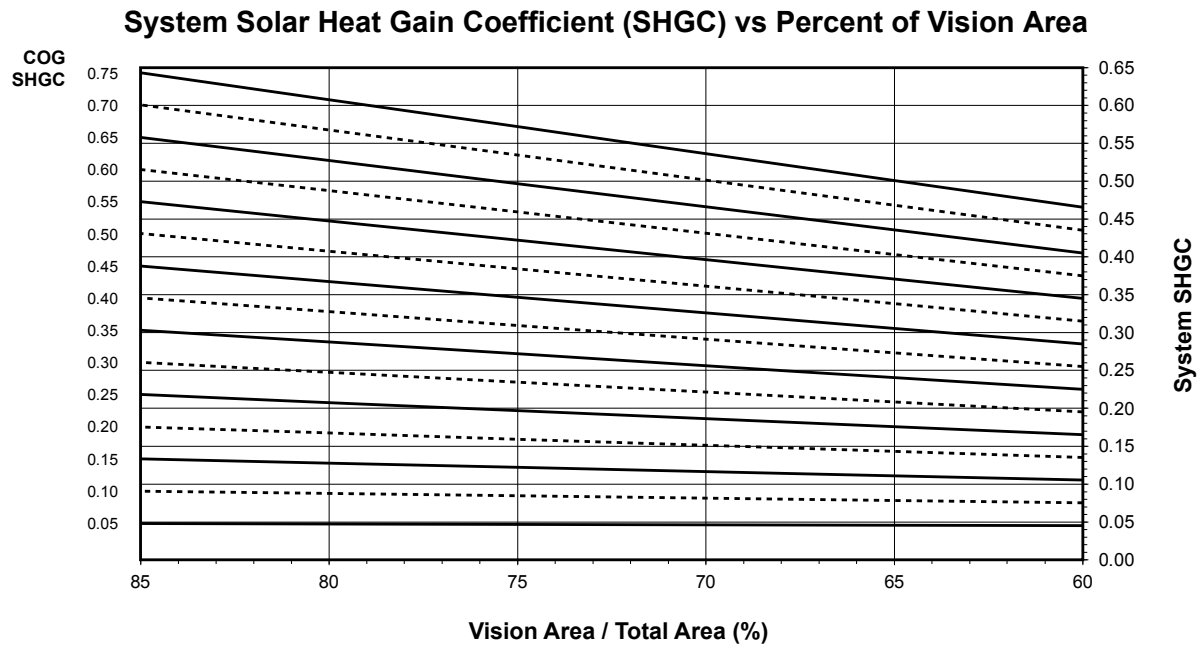

See [Note, page 62](#).

Solar Heat Gain Coefficient (SHGC) Matrix

Glass SHGC ^{a. b. c.}	Overall SHGC ^{d.}
0.75	0.57
0.70	0.53
0.65	0.50
0.60	0.46
0.55	0.42
0.50	0.38
0.45	0.35
0.40	0.31
0.35	0.27
0.30	0.23
0.25	0.20
0.20	0.16
0.15	0.12
0.10	0.08
0.05	0.05

^{a.} SHGC values are determined in accordance with NFRC 200.

^{b.} For glass values that are not listed, linear interpolation is permitted.

^{c.} Glass properties are based on center-of-glass values and are obtained from your glass supplier.

^{d.} Overall SHGC values are based on the standard NFRC specimen size of 1,500 mm wide by 600 mm high (59-1/6" by 23-5/8").

System Visible Transmittance (VT) - CW (Shallow) - Project-Out Window with 1-3/4" Glazing

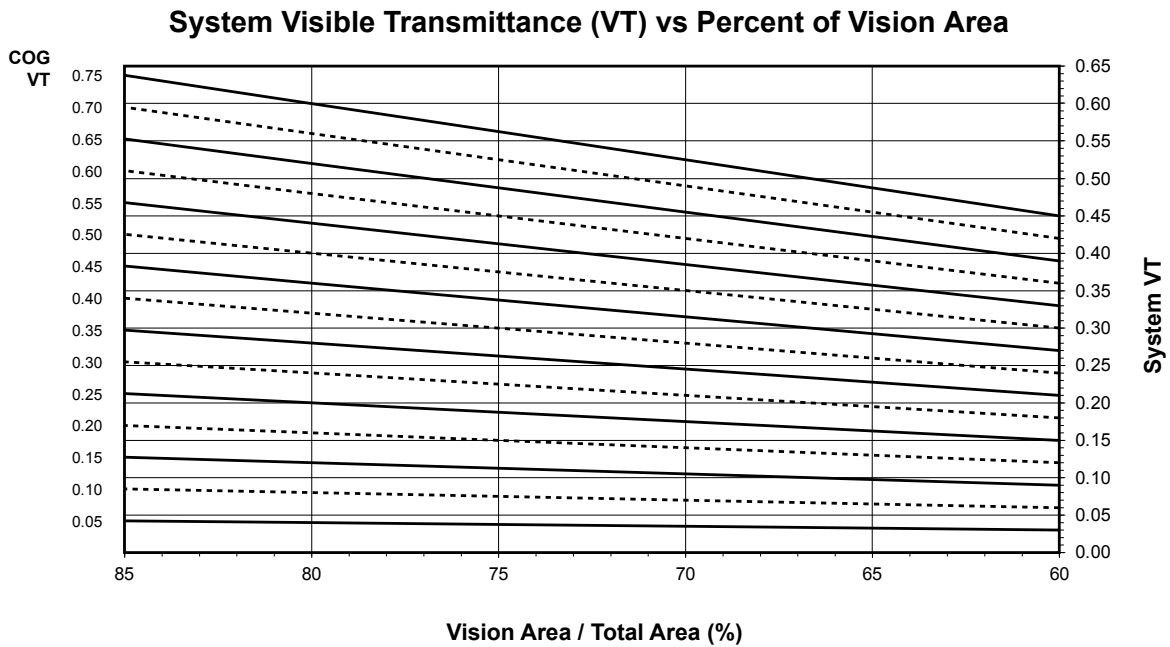

See [Note, page 62](#).

Visible Transmittance (VT)

Glass VT ^{a. b. c.}	Overall VT ^{d.}
0.75	0.56
0.70	0.52
0.65	0.49
0.60	0.45
0.55	0.41
0.50	0.37
0.45	0.34
0.40	0.30
0.35	0.26
0.30	0.22
0.25	0.19
0.20	0.15
0.15	0.11
0.10	0.07
0.05	0.04

^{a.}VT values are determined in accordance with NFRC 200.

^{b.}For glass values that are not listed, linear interpolation is permitted.

^{c.}Glass properties are based on center-of-glass values and are obtained from your glass supplier.

^{d.}Overall VT values are based on the standard NFRC specimen size of 1,500 mm wide by 600 mm high (59-1/6" by 23-5/8").

CW (Shallow) - Outswing Casement Window with 1" Glazing (Aluminum Glazing Spacer)



NOTE

These notes apply to the charts for system U-factor, solar heat gain coefficient (SHGC), and visible transmittance (VT):

- Values in parentheses are metric.
- COG = Center of Glass
- Charts are generated per AAMA 507.
- For glass values that are not listed, linear interpolation is permitted.
- Glass properties are based on center-of-glass values and are obtained from your glass supplier.

System U-factor for Glass Area

System U-factor vs Percent of Glass Area

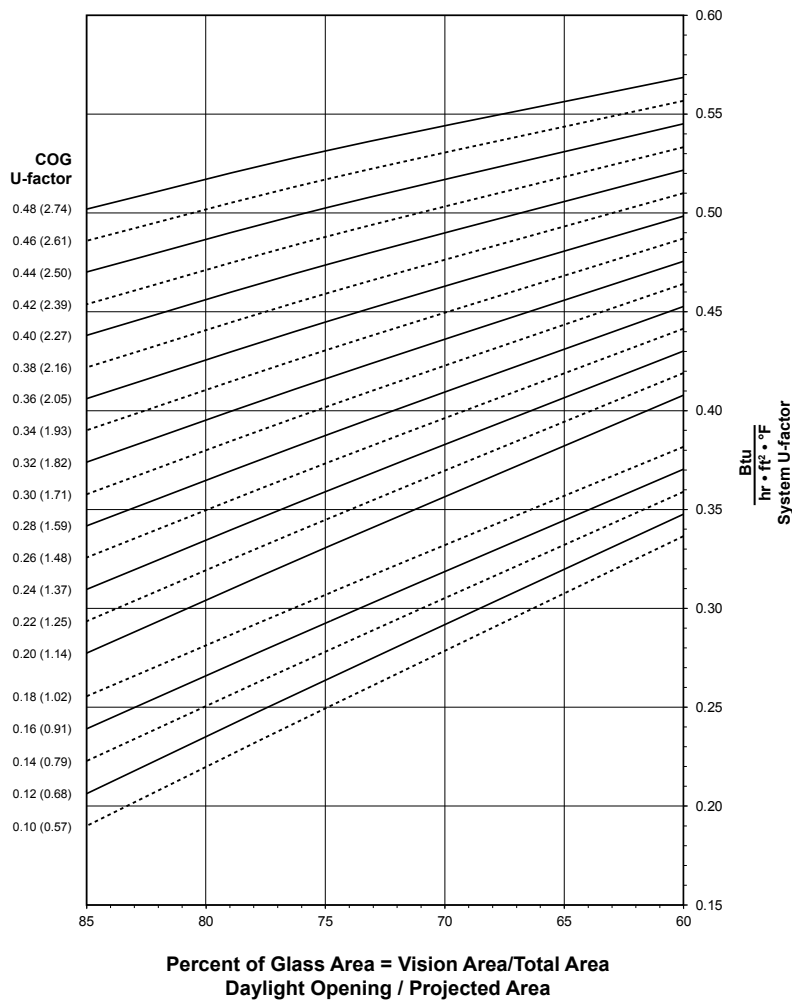

See Note, page 66.



CW (Shallow) - Outswing Casement Window with 1" Glazing**Thermal Transmittance (BTU/hr • ft² • °F)**

Glass U-factor ^{a. b. c.}	Overall U-factor ^{d.}
0.48	0.53
0.46	0.52
0.44	0.50
0.42	0.49
0.40	0.47
0.38	0.46
0.36	0.45
0.34	0.43
0.32	0.42
0.30	0.40
0.28	0.39
0.26	0.37
0.24	0.36
0.22	0.35
0.20	0.33
0.18	0.31
0.16	0.29
0.14	0.28
0.12	0.27
0.10	0.25

^{a.}U-factor values are determined in accordance with NFRC 100.

^{b.}For glass values that are not listed, linear interpolation is permitted.

^{c.}Glass properties are based on center-of-glass values and are obtained from your glass supplier.

^{d.}Overall U-factor values are based on the standard NFRC specimen size of 1,500 mm wide by 600 mm high (59-1/6" by 23-5/8").

System Solar Heat Gain Coefficient (SHGC) - CW (Shallow) - Outswing Casement Window with 1" Glazing

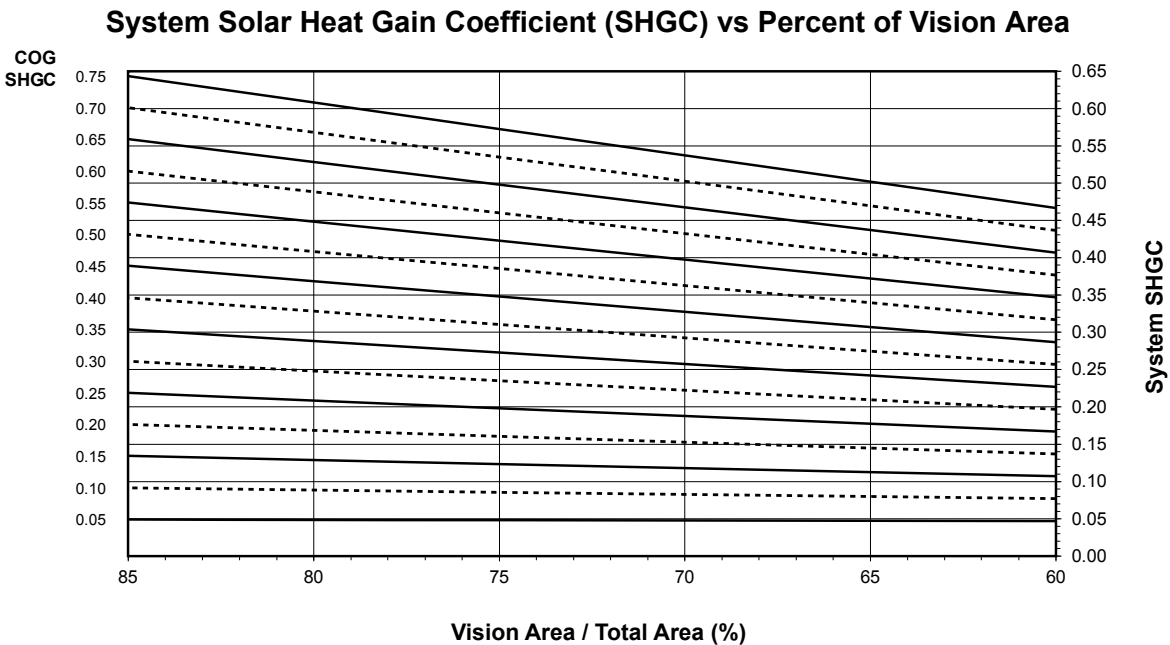

See [Note, page 66](#).

Solar Heat Gain Coefficient (SHGC) Matrix

Glass SHGC ^{a, b, c}	Overall SHGC ^d
0.75	0.57
0.70	0.53
0.65	0.50
0.60	0.46
0.55	0.42
0.50	0.38
0.45	0.35
0.40	0.31
0.35	0.27
0.30	0.23
0.25	0.20
0.20	0.16
0.15	0.12
0.10	0.09
0.05	0.05

^a SHGC values are determined in accordance with NFRC 200.

^b For glass values that are not listed, linear interpolation is permitted.

^c Glass properties are based on center-of-glass values and are obtained from your glass supplier.

^d Overall SHGC values are based on the standard NFRC specimen size of 1,500 mm wide by 600 mm high (59-1/8" by 23-5/8").

System Visible Transmittance (VT) - CW (Shallow) - Outswing Casement Window with 1" Glazing

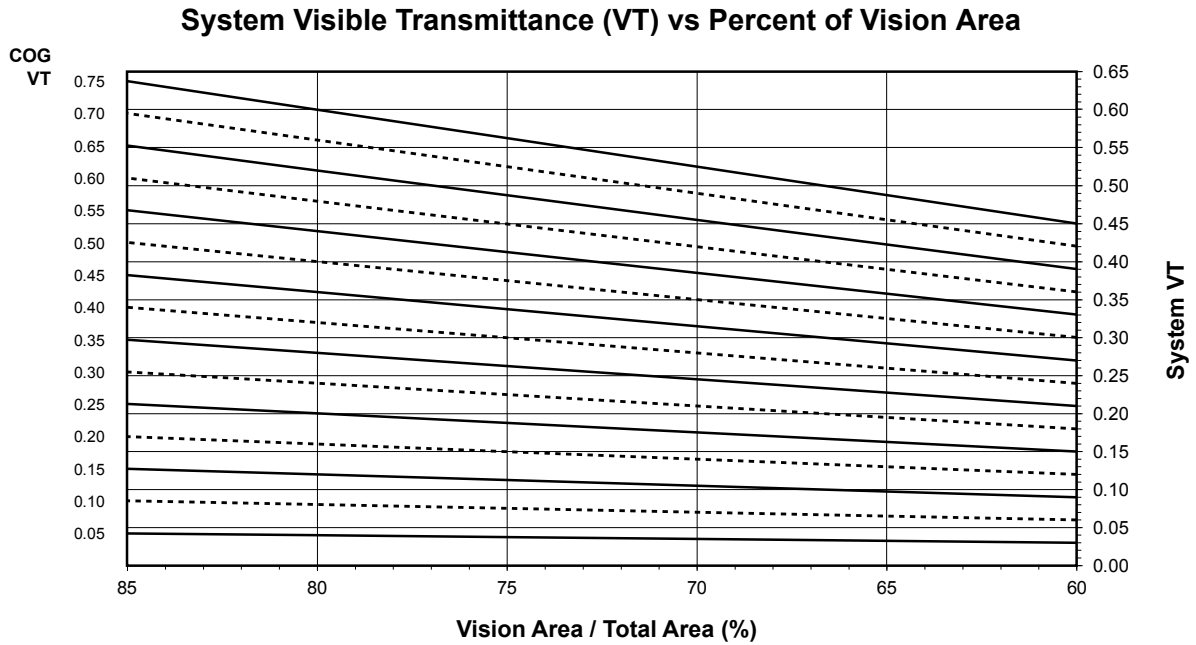

See [Note, page 66](#).

Visible Transmittance (VT)

Glass VT ^{a. b. c.}	Overall VT ^{d.}
0.75	0.56
0.70	0.52
0.65	0.49
0.60	0.45
0.55	0.41
0.50	0.37
0.45	0.34
0.40	0.30
0.35	0.26
0.30	0.22
0.25	0.19
0.20	0.15
0.15	0.11
0.10	0.07
0.05	0.04

^{a.}VT values are determined in accordance with NFRC 200.

^{b.}For glass values that are not listed, linear interpolation is permitted.

^{c.}Glass properties are based on center-of-glass values and are obtained from your glass supplier.

^{d.}Overall VT values are based on the standard NFRC specimen size of 1,500 mm wide by 600 mm high (59-1/6" by 23-5/8").

CW (Shallow) - Outswing Casement Window with 1-3/4" Glazing (Aluminum Glazing Spacer)



NOTE

These notes apply to the charts for system U-factor, solar heat gain coefficient (SHGC), and visible transmittance (VT):

- Values in parentheses are metric.
- COG = Center of Glass
- Charts are generated per AAMA 507.
- For glass values that are not listed, linear interpolation is permitted.
- Glass properties are based on center-of-glass values and are obtained from your glass supplier.

System U-factor for Glass Area

System U-factor vs Percent of Glass Area

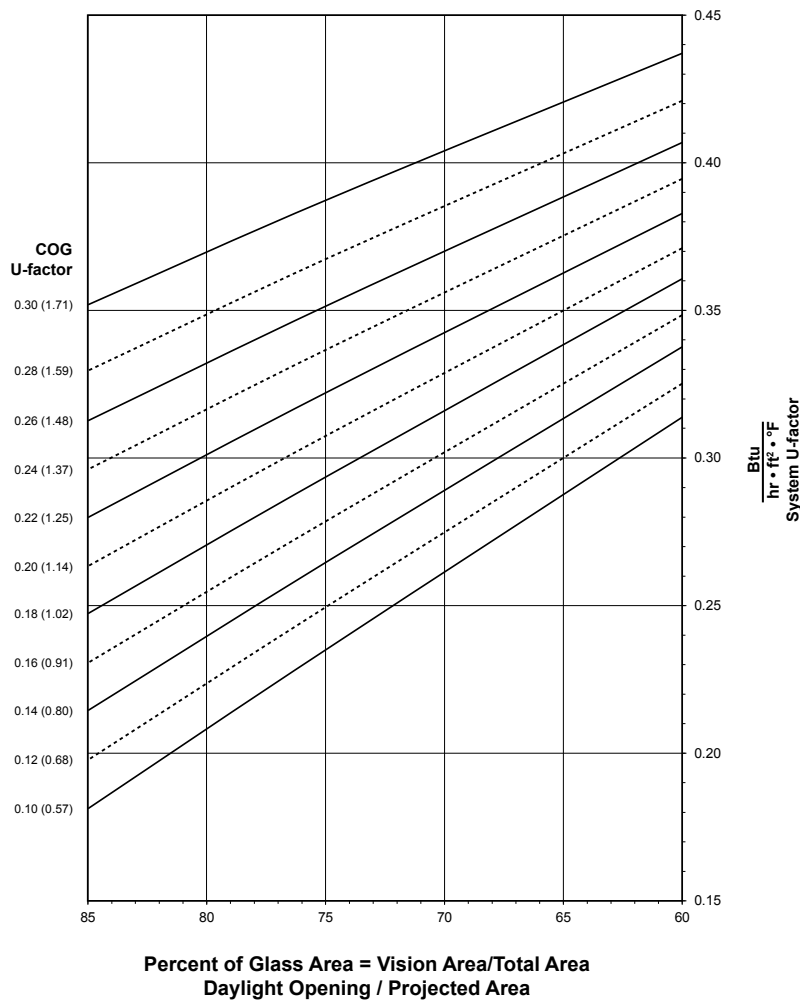

See Note, page 70.



CW (Shallow) - Outswing Casement Window with 1-3/4" Glazing**Thermal Transmittance (BTU/hr • ft² • °F)**

Glass U-factor ^{a. b. c.}	Overall U-factor ^{d.}
0.31	0.39
0.28	0.37
0.26	0.35
0.24	0.34
0.22	0.32
0.20	0.31
0.18	0.29
0.16	0.28
0.14	0.27
0.12	0.25
0.10	0.24

^{a.}U-factor values are determined in accordance with NFRC 100.

^{b.}For glass values that are not listed, linear interpolation is permitted.

^{c.}Glass properties are based on center-of-glass values and are obtained from your glass supplier.

^{d.}Overall U-factor values are based on the standard NFRC specimen size of 1,500 mm wide by 600 mm high (59-1/6" by 23-5/8").

System Solar Heat Gain Coefficient (SHGC) - CW (Shallow) - Outswing Casement Window with 1-3/4" Glazing

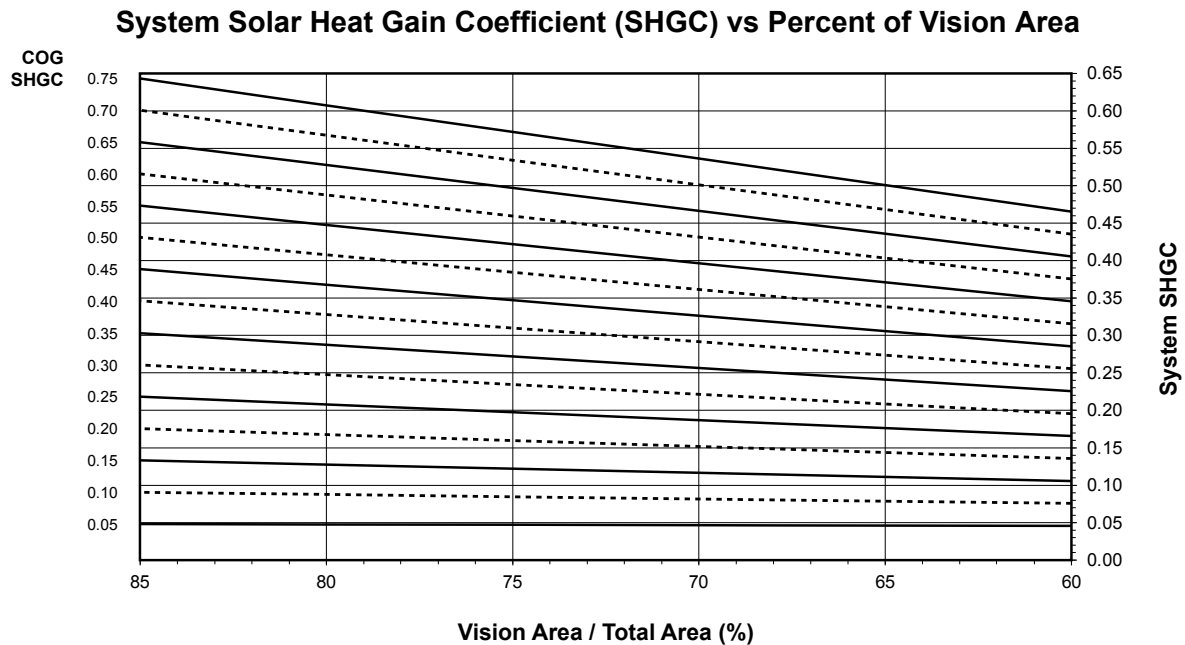

See [Note, page 70](#).

Solar Heat Gain Coefficient (SHGC) Matrix

Glass SHGC ^{a, b, c}	Overall SHGC ^d
0.75	0.57
0.70	0.53
0.65	0.50
0.60	0.46
0.55	0.42
0.50	0.38
0.45	0.35
0.40	0.31
0.35	0.27
0.30	0.23
0.25	0.20
0.20	0.16
0.15	0.12
0.10	0.08
0.05	0.05

^a SHGC values are determined in accordance with NFRC 200.

^b For glass values that are not listed, linear interpolation is permitted.

^c Glass properties are based on center-of-glass values and are obtained from your glass supplier.

^d Overall SHGC values are based on the standard NFRC specimen size of 1,500 mm wide by 600 mm high (59-1/6" by 23-5/8").

System Visible Transmittance (VT) - CW (Shallow) - Outswing Casement Window with 1-3/4" Glazing

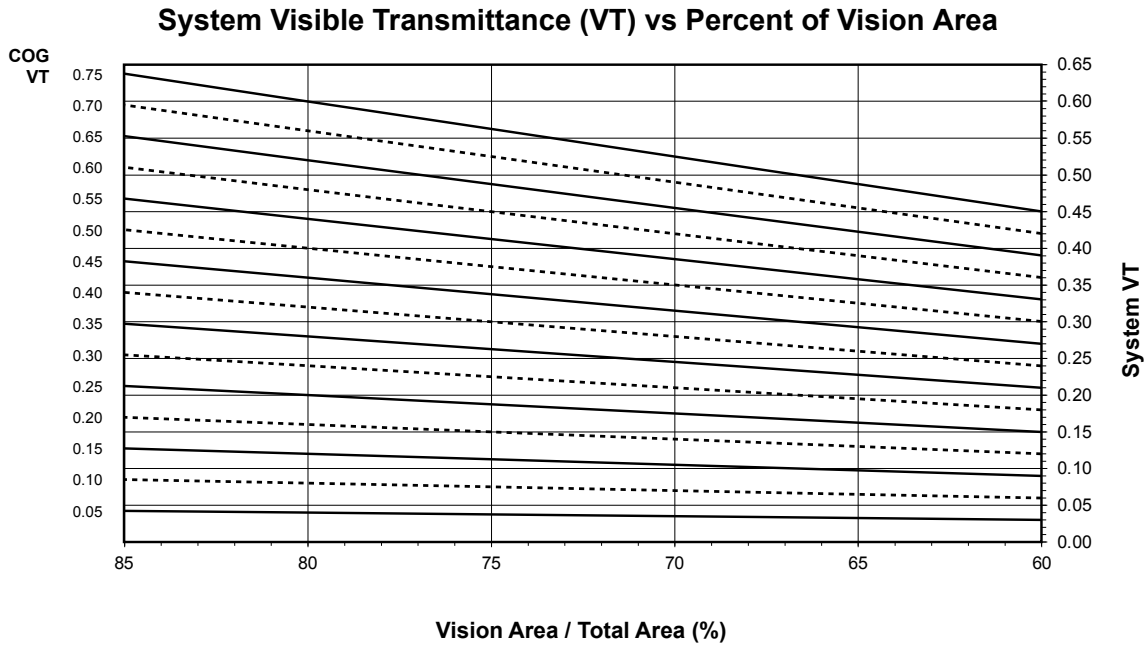

See [Note, page 70](#).

Visible Transmittance (VT)

Glass VT ^{a. b. c.}	Overall VT ^{d.}
0.75	0.56
0.70	0.52
0.65	0.49
0.60	0.45
0.55	0.41
0.50	0.37
0.45	0.34
0.40	0.30
0.35	0.26
0.30	0.22
0.25	0.19
0.20	0.15
0.15	0.11
0.10	0.07
0.05	0.04

^{a.}VT values are determined in accordance with NFRC 200.

^{b.}For glass values that are not listed, linear interpolation is permitted.

^{c.}Glass properties are based on center-of-glass values and are obtained from your glass supplier.

^{d.}Overall VT values are based on the standard NFRC specimen size of 1,500 mm wide by 600 mm high (59-1/6" by 23-5/8").

Notes And Disclaimers

Laws and building and safety codes governing the design and use of Kawneer products, such as glazed entrance, window, and curtain wall products, vary widely. Kawneer does not control the selection of product configurations, operating hardware, or glazing materials, and assumes no responsibility therefor. It is the responsibility of the owner, the specifier, the architect, the general contractor, and the installer and the fabricator/transformer, consistent with their roles, to determine the appropriate materials for a project in strict conformity to all applicable national, regional and local building codes and regulations.

Kawneer reserves the right to change configuration without prior notice when deemed necessary for product improvement.

Information contained herein or related hereto is intended only for evaluation by technically skilled persons, with any use thereof to be at their independent discretion and risk. Such information is believed to be reliable, but Kawneer shall have no responsibility or liability for results obtained or damages resulting from such use.

Kawneer grants no license under, and shall have no responsibility or liability for infringement of, any patent or other proprietary right. Nothing in this document should be construed as a warranty or guarantee by Kawneer, and the only applicable warranties will be those set forth in Kawneer acknowledgment or in any printed warranty documents issued by Kawneer. The foregoing may be waived or modified only in writing by a Kawneer officer.

© 2020, Kawneer Company, Inc.